

The results of the study of the qualitative parameters of the multifunctional seeding machine

*Azamat E. Bogus**, *Vladimir I. Konovalov*, *Vladislav D. Stanin*, and *Vladimir A. Rusnak*

Kuban State Agrarian University named after I.T.Trubilin, 350044 Krasnodar, Russia

Abstract. The article presents a constructive scheme of a multifunctional seeding apparatus and substantiates the relevance of its use for agricultural producers of the Southern Federal district with a total area of arable land up to 50-70 hectares. This multifunctional seeding machine allows sowing in various ways for each crop. To assess the qualitative performance of the multifunctional seeding machine in Kuban State University named after I. T. Trubilin, a private methodology and experimental setup were developed at the PriMa department. A mathematical model of the frequency of a single seed supply by a multifunctional seeding machine for sowing corn and wheat has been developed. The parameters for the rational mode of operation of the multifunctional sowing machine for sowing wheat and corn have been determined: the rotation frequency of the disk n , the pressure in the seed chamber P and the frequency of a single seed supply is M for sowing wheat and corn. It was found that the frequency of a single seed supply during wheat sowing is more influenced by the value of excess pressure in the seed chamber. The frequency of a single seed supply during corn sowing is greatly influenced by the value of excess pressure in the seed chamber.

1 Introduction

The plant-growing enterprises of the Southern Federal district are engaged in the cultivation of winter wheat and barley, corn for grain, rapeseed, sunflower soybeans. One of the features of the cultivation of these crops is the various ways of sowing them, such as ordinary, strip, wide-row dotted. These key agrotechnological features lead to the need to use different sowing units equipped with different types of sowing machines, coulter groups and sowing sections. Since the vast majority of agricultural producers of the Southern Federal district with a total area of arable land up to 50-70 hectares do not use monoculture in the structure of crops, this leads to a low annual load of these seeders. This is through deductions for depreciation, maintenance and repairs inevitably affect the final cost of production. It should also be noted that often, due to the high cost of sowing machines, small agricultural producers are not able to purchase the required agricultural machinery, in addition, this is most often not economically feasible. The use of hired machines does not

* Corresponding author: bogus.a@edu.kubsau.ru

allow sowing in the specified agrotechnical terms, which significantly reduces their productivity and quality parameters.

2 Analysis of designs of pneumatic seeding machines

Based on the analysis of promising designs of seeding machines [1, 2, 3], we have proposed a design and technological scheme of a multifunctional seeding machine (Fig. 1) that allows performing dosing of seeds of various crops for different sowing methods.

In the laboratory of the PriMa department of Kuban State University named after I. T. Trubilin, a methodology and experimental setup were developed (Fig. 2) [4] to study the operation of the proposed multifunctional seeding units.

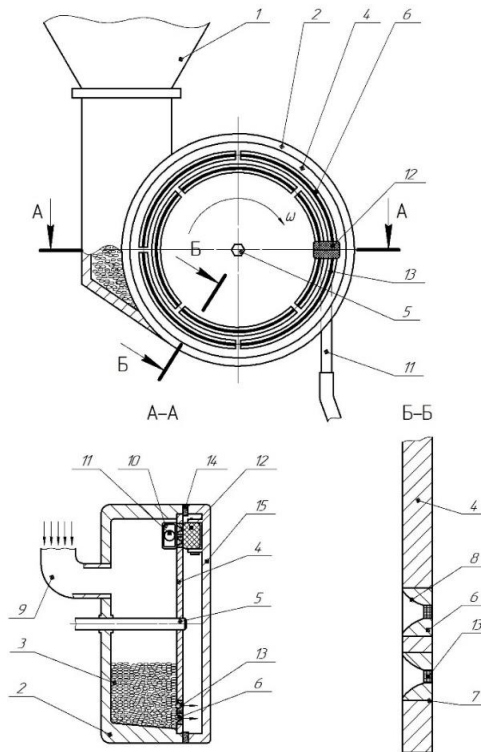

1 – hopper; 2 – housing; 3 – seed chamber; 4 – sowing disk; 5 – drive shaft; 6 – metering elements; 7 – seats; 8 – recesses; 9 – air overpressure channel; 10 – intake device; 11 – tube; 12 – nodes for overlapping recesses

Fig. 1. Multifunctional seeding machine (MSM)

The quality of the multifunctional seeding machine was evaluated by counting the frequencies of: single seed feed (p_1); double feed (p_2); zero feed (p_0); coefficient of variation of seed feed (V) and average seed feed (M).

Factors and levels of variation in the study of a multifunctional seeding apparatus were selected based on a priori information and a series of preliminary experiments (Table 1).

A composite D-optimal orthogonal Boxing plan- B^3 was chosen to analyze the influence of factors on seed supply. The experiments were carried out in threefold repetition, 200 seeds were sown in each experiment.

Table 1. Factors and levels of variation in the study of a multifunctional seeding machine

Name of the factor	Designation	Variation interval	Levels of factors		
			low	zero	high
For wheat seeds					
Air pressure in the seed chamber (P, kPa)	x1	1	3	4	5
Rotation frequency of the sowing disk (n, s ⁻¹)	x2	1	1.5	2.5	3.5
For corn seeds					
Air pressure in the seed chamber (P, kPa)	x1	1	3	4	5
Rotation frequency of the sowing disk (n, s ⁻¹)	x2	0.1	0.2	0.3	0.4

The experiments carried out made it possible to determine the optimal operating modes of the multifunctional seeding unit [5, 6].

During the operation of the experimental installation, seeds from the seed box 2 are dosed with a multifunctional sowing apparatus, after which the seeds are fed to the tape 8, with a sticky surface fixed on it. The seeding machine works in conjunction with an excess current source – a fan 6, the rotation frequency of which is changed by a frequency converter 7. The drive of the seeding disk is carried out from a DC motor 3, the frequency of which varies by a rheostat 4.

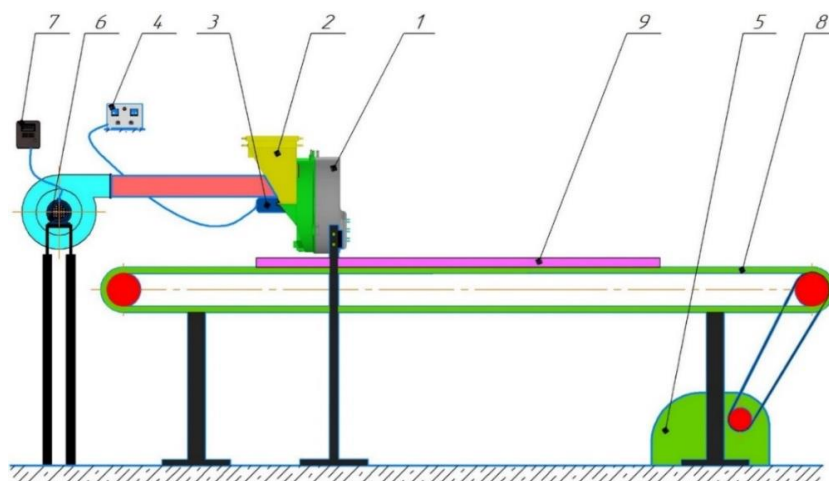

1 – multifunctional sowing machine; 2 – seed box; 3 – electric drive of the sowing disk; 4 – rectifier with rheostat; 5 – gearbox; 6 – fan; 7 – frequency converter; 8 – tape; 9 – glue

Fig. 2. Diagram of an experimental installation for research multifunctional seeding machine

To analyze the quality of the multifunctional seeding machine, 200 seeds were sown on a tape covered with glue, after which the frequencies were recorded: single seed feeds (p_1),

double feeds (p_2), zero feeds (p_0) by measuring the distance between the seeds (Fig. 3 and 4).

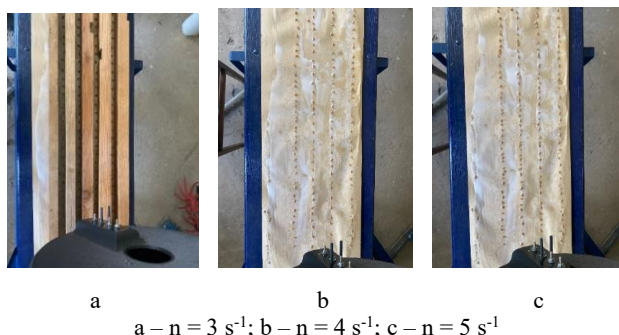

Fig. 3. Study of the quality of the MBA when sowing wheat at different values of the rotation speed of the sowing disk

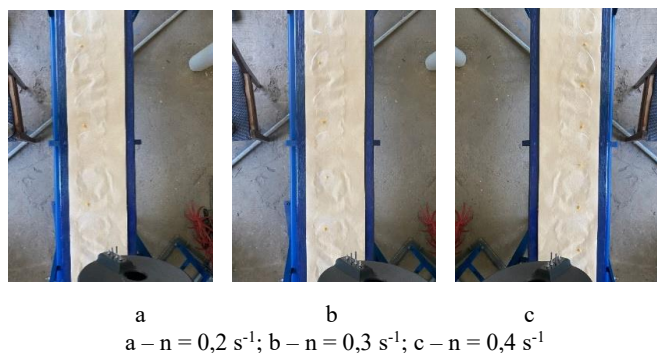

Fig. 4. Study of the quality of the MSM when sowing corn at different values of the rotation frequency of the sowing disk

3 Analysis of research results

The results of the study of the qualitative parameters of the multifunctional seeding machine are presented in Table 2.

Table 2. Results of experimental studies of qualitative parameters of the MSM

№	X_1	X_2	wheat				corn			
			Probability			M_w	probability			M_c
			p_0	p_1	p_2		p_0	p_1	p_2	
1	+	+	0,02	0,9	0,08	1,06	0,05	0,83	0,12	1,07
2	-	+	0,06	0,9	0,04	0,98	0,08	0,83	0,09	1,01
3	+	-	0	0,88	0,12	1,12	0,02	0,84	0,14	1,12
4	-	-	0,04	0,89	0,07	1,03	0,05	0,85	0,1	1,05
5	0	+	0,05	0,92	0,03	0,98	0,08	0,87	0,04	0,97
6	0	-	0,04	0,93	0,03	0,99	0,06	0,9	0,04	0,98
7	+	0	0	0,92	0,08	1,08	0,01	0,88	0,11	1,1
8	-	0	0,06	0,93	0,01	0,95	0,05	0,88	0,07	1,02
9	0	0	0,02	0,95	0,03	1,01	0,02	0,9	0,08	1,06

To substantiate the assessment of the influence of factors on the planning matrix and the results of the experiment, regression equations were calculated [1].

In the encoded form: nt

$$y_w = 0,984 + 0,05x_1 - 0,02x_2 - 2,5 \cdot 10^{-3} x_1 x_2 + 0,043x_1^2 + 0,013x_2^2 \tag{1}$$

$$y_c = 1,021 + 0,035x_1 - 0,017x_2 - 2,5 \cdot 10^{-3} x_1 x_2 + 0,058x_1^2 - 0,027x_2^2 \tag{2}$$

where y – the frequency of a single seed supply when sowing wheat and corn, respectively;

x_1 and x_2 – accordingly, the rotation frequency of the sowing disk and the value of the excess pressure in the seed chamber.

Regression equations in natural units:

$$M_w = 1,399 + 0,157n - 0,12P - 2,5 \cdot 10^{-3} nP + 0,043n^2 + 0,013P^2 \tag{3}$$

$$M_c = 1,594 - 0,424n^{-1} + 0,533P - 0,025nP + 0,058n^2 - 2,667P^2 \tag{4}$$

where y – frequency of single seed supply; n – rotation frequency of the seeding disk, s^{-1} ; P – the value of excess pressure in the seed chamber, kPa

The adequacy of the obtained coefficients is confirmed by the Kohren criterion, with a three-fold repetition of experiments and a degree of freedom equal to 4, the tabular value is $G_T = 0,391$, and for the resulting models, respectively $G_{T1} = 0,275$ and $G_{T2} = 0,238$;

The optimal parameters of the multifunctional seeding machine were calculated:

When sowing wheat: $n = 4,7 s^{-1}$; $P = 1,9 kPa$.

When sowing corn: $n = 0,3 s^{-1}$; $P = 3,69 kPa$.

With an optimal combination of the studied factors for the value of the particular single seed supply during sowing of wheat and corn, response surfaces and their cross-sections were constructed (Fig. 5 and 6).

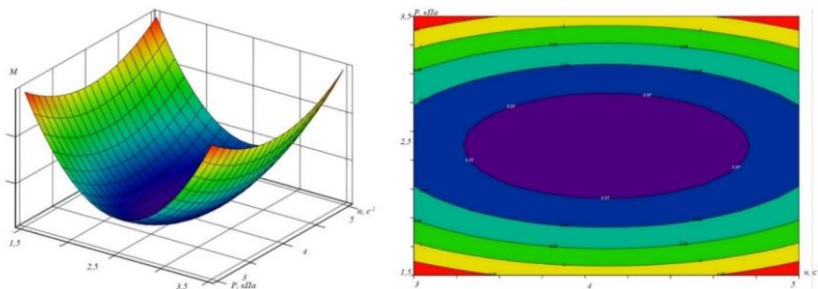

Fig. 5. The influence of the rotation frequency of the sowing disk and the values of excess pressure in the seed chamber on the frequency of a single seed supply during wheat sowing

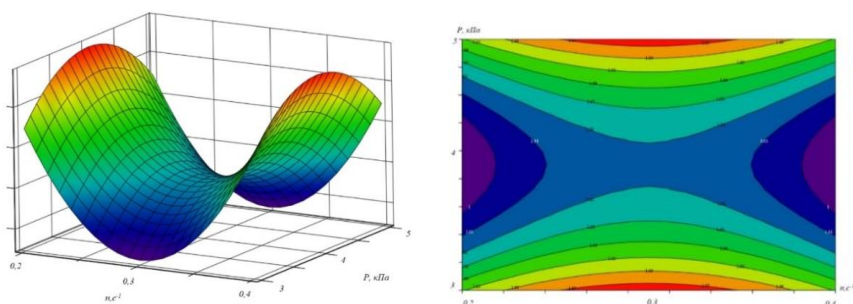

Fig. 6. The influence of the rotation frequency of the sowing disk and the values of excess pressure in the seed chamber on the frequency of a single seed supply during corn sowing

4 Conclusions

Analyzing the data obtained, it can be argued that the frequency of a single seed supply during wheat sowing is more influenced by the value of excess pressure in the seed chamber. Under certain rational modes of operation for wheat: the rotation frequency of the sowing disk, $n = 4.7 s^{-1}$ and the value of excess pressure in the seed chamber, $P = 1.9 kPa$, the frequency of a single seed supply $M = 0.99$.

The frequency of a single seed supply during corn sowing is greatly influenced by the value of excess pressure in the seed chamber. Under certain rational operating modes for corn: the rotation frequency of the sowing disk, $n = 0.33 s^{-1}$ and the value of excess pressure in the seed chamber, $P = 3.69 kPa$, while the frequency of a single seed supply is $M = 1.02$.

References

1. Bogus A. E. Analysis of the process of operation of distribution devices of grain pneumatic seeders / A. E. Bogus // proceedings based on the materials of the 73rd scientific and practical conference of teachers. – 2018. – pp. 267-268.
2. Bogus A.E. Theoretical studies of the movement of seeds in the distribution system of a pneumatic grain drill [Text] / A. E. Bogus // Multidisciplinary network electronic scientific journal of Kuban State Agrarian University. 2020. No.158. pp.1-12.
3. Klenin, N. I. Agricultural machines [Text] / N.I. Klenin, S.N. Kiselyov, A.G. Levshin; – M.: Kolos, 2008. – 652 p.
4. Kryuchin, N. P. Sowing machines. Design features and development trends [Text]: textbook. manual / N.P. Kryuchin – Samara: RIC GSHA, 2009. – 176 p.
5. Lobachevsky P. Ya. Regularities of feeding technological material with discrete dispensers [text] / P. Ya.Lobachevsky // Herald of Russian Academy of Agricultural Sciences, 1999, No. 6, pp. 33-35.
6. Khalansky V. M. Agricultural machines: textbook [Text] / V. M. Khalansky, I. V. Gorbachev – M.: Kolos, 2004 – 624 p.