

# Autoregulatory of water level for channels of parabolic section and its capacity

*Mukaddas-Gaukhar* Kadirova \*

"Tashkent Institute of Irrigation and Agricultural Mechanization Engineers" National Research University, Tashkent Uzbekistan

**Abstract.** The proposed design of the water level autoregulator with flexible working bodies for the channels of the parabolic section of the irrigation system is made in the form of a gate, which is a container formed by a rigid bottom, a pressure part made of flexible rubberized meliorative fabric, a rigid frame part of the spillway with a non-vacuum type profile covered with flexible meliorative fabric, and soft side elements also made of flexible rubberized meliorative fabric, which are a continuation of the pressure and spillway parts. Regulation of the water level in front of the autoregulator is carried out using a water level regulator. To determine the flow capacity of the gate of the proposed design of the water level autoregulator, a theoretical formula was derived, and experimental studies were carried out to determine the values of the flow coefficient included in this formula. The study was carried out on an experimental installation by the physical modeling method of the model and nature. As a result of the mathematical processing of the results of studies of the shutter model, an empirical formula was obtained for determining the shutter flow rate depending on the ratio of the iridescent water layer's thickness to the shutter's height. At the same time, the difference between the obtained values of the flow coefficients according to this formula and the results of experimental studies was +4...5 percent. This automatic water level regulator performs the function of a partition structure, does not require high costs, and can be portable and stationary; it is not metal-intensive, lightweight, transportable, combines the functions of stabilizing the required water level in the channel, dumping excess water, fin and debris, provides the necessary water enters the outlet openings of the channel.

## 1 Introduction

Currently, much attention is paid to the issues of uninterrupted operation, continuous modernization of irrigation systems and other water management and hydraulic structures, the development and implementation of modern innovative and resource-saving technologies in the water sector, improving the efficiency of the operation of structures on irrigation canals described in the works of Y.E. Pulatov [1], T.S. Koshkarova, L.N. Medvedeva, A.A. Novikov, L.A. Voevodina [2], V.N. Shchedrin, S.M. Vasilyev, A.A. Churaev [3], A.A. Aldoshkin [4], E.M. Khalifa, M.A. Eltavil, M.E. Melekh, M.M. Sharaf

---

\*Corresponding author: [mukaddas-gauhar1952@yandex.ru](mailto:mukaddas-gauhar1952@yandex.ru)

[5], P.P. Gadge, V. Jothiprakash and V.V. Bhosekar [6]. To maintain the required water level in front of the partition structures and supply a given constant water flow to the outlets for economical consumption of water to consumers, automation of partition structures on channels is carried out, described in the works of K.M. Melikhov, A.A. Pakhomov, N.A. Kolobanov [7], V.N. Shchedrin, A.A. Churaev, V.M. Shkolnaya, L.V. Yuchenko [8], V.I. Olgarenko, N.S. Stepanov, O.P. Kisarov, I.V. Olgarenko [9], M.I. Balzannikov [10]. Based on the features of existing partition structures, the mass use of gates on the partition structures of irrigation systems, and their remote location from power lines, among them, from the point of view of economic efficiency, hydraulic automation of them is the most suitable, that is, equipping them with automatic hydraulic gates, hydraulic autoregulators of the water level, operating entirely on renewable hydraulic energy of the water flow. They provide economical water consumption, energy savings spent on their operation, and reduced operating costs. Only some designs of automatic hydraulic gates described in the well-known works of Ya.V. Bochkarev, P.I. Kovalenko, E.E. Makovsky, and others have found applications in partition structures of irrigation channels. They are made of traditional metal materials. Their peculiarity is metal gates (flat, segmental, valve, sector) of a certain design, the requirement for them to have significant water level drops that prevent water from overflowing through the upper part of the gate, the need for periodic mechanical cleaning of the space in front of the gate from floating bodies and debris, the need for capital structures. This is expensive and prevents their widespread introduction into production. The creation of flexible rubberized fabrics as a new type of building material having low weight, flexibility, the ability to change shape with load changes, and high maneuverability, such as those shown in the work of T. Tomiyama and I. Nishizaki [11], create great prospects for their use as flexible organs in hydraulic autoregulators of the water level. Therefore, today there are combined flexible designs of automatic hydraulic valves and automatic water level regulators. These constructions are highlighted in the well-known works of O.G. Zatzornitsky, B.I. Sergeev and shown in the works of V.I. Loginov, S.M. Rtishchev, V.N. Kozyrev, M.V. Ilemenov, E.D. Mikhailova [12], M.-G.A. Kadirova [13, 14, 15, 16]. The main disadvantage of using them on channels of the parabolic cross-section is the inconvenient parabolic cross-section of the channel for installing such automatic gates and the need for periodic mechanical cleaning of this section from floating bodies and debris in front of the automatic gate. Therefore, implementing all these structures on the tray channels of irrigation systems of a parabolic cross-section is difficult. Therefore, today there is an interest in finding simpler designs of such hydraulic automatic gates and automatic water level regulators for channels of a parabolic section of the irrigation system, the designs of which differ in the absence of metal consumption, ease, cheapness, maintainability, environmental cleanliness and, if necessary, the ability to transfer them from place to place.

Based on the analysis of existing and proposed designs of automatic gates for irrigation system channels, the task was set to develop a design of an autoregulator of the water level for irrigation system channels of parabolic cross-section (trays), operating entirely due to the hydraulic energy of the water flow, automatically regulating the water level along the length of the channel to the place of its installation, ensuring the passage of excess water, floating bodies and garbage, which is non-metal-intensive, lightweight and, if necessary, mobile, and also determine its throughput.

Based on the task, it was necessary to solve the following issues: to choose a suitable initial design of the water level autoregulator, on its basis to develop a new innovative design of the water level autoregulator with flexible working bodies for the channels of the parabolic section of the irrigation network, to propose a formula for determining the throughput of the developed design, to choose the scale of the experimental installation and models, to determine their dimensions by physical modeling, perform an experimental

setup and models to study the developed design, conduct model studies on an experimental installation to determine the throughput capacity of the structure, perform mathematical processing of the results of experimental studies.

Based on the task, it was necessary to solve the following issues: to choose a suitable initial design of the water level autoregulator, on its basis to develop a new innovative design of the water level autoregulator with flexible working bodies for the channels of the parabolic section of the irrigation network, to propose a formula for determining the throughput of the developed design, to choose the scale of the experimental installation and models, to determine their dimensions by physical modeling, perform an experimental setup and models to study the developed design, conduct model studies on an experimental installation to determine the throughput capacity of the structure, perform mathematical processing of the results of experimental studies.

## 2 Methods

Based on this goal, we have chosen a suitable initial design in the form of a design developed earlier jointly with F.A. Kadirov [17], an autoregulator of the water level on the canal. She created the conditions for developing the design of an autoregulator of the water level with flexible working bodies for the channels of the parabolic section of the irrigation network (trays). The developed design of the water level autoregulator with flexible working bodies for the channel of the parabolic section of the irrigation network is shown in Fig. 1.

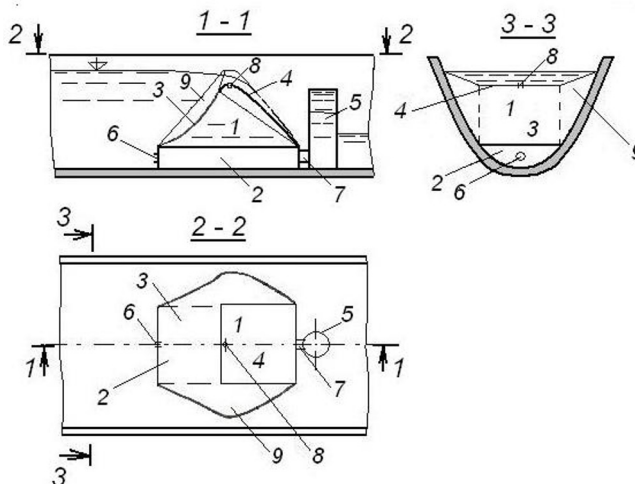

**Fig. 1.** Design of automatic partition structure in form of autoregulator of water level with flexible working bodies for channels of parabolic cross-section (trays): 1 is capacity of gate, 2 is bottom of gate, 3 is pressure part of gate, 4 is spillway part of gate, made in form of non-vacuum profile, 5 is water level setter, made in form of vertical pipe with open top, 6 is inlet, 7 is pipe, 8 is air outlet, 9 is side elements of gate.

The design of the automatic partition structure in the form of an automatic water level regulator (figure 1) is made in the form of a gate filled with water during its operation, the reservoir 1 of which is formed by the bottom 2, the front part 3 and the spillway part 4. The bottom 1 is made in the form of a rigid channel bottom.

Parts 3 and 4 are made of flexible rubberized meliorative fabric. At the same time, part 3 is under water pressure. The level above in front of the structure is regulated using a

water level regulator 5, made in the form of a vertical pipe with an open top installed behind the gate. It communicates with the capacity of the gate using a pipe 7. Filling the capacity of the water-containing shutter occurs through the inlet 6, through which water from the part of the channel in front of the gate constantly enters the reservoir of the gate. To ensure the normal operation of the water level autoregulator, the area of the inlet opening 6 should be 3..4 times smaller than the area of the pipe opening 7. To ensure vibration-free, stable operation of the autoregulator of the water level, the spillway part 4 of the gate is made in the form of a rigid frame in the form of a non-vacuum profile of the spillway. It is covered with a flexible rubberized meliorative fabric passing into the side of flexible elements 9, which are simultaneously a continuation of the clamping part 3 of the gate. In this case, the side elements 9, as well as the clamping part 3 of the shutter, are made of flexible rubberized meliorative fabric, and the width of the spillway part 4 of the shutter is equal to the width of the bottom part 2 of the gate in the upper part.

When changing the position of the shutter, for example, opening it, the pressure part 3 and the side elements 9 of the spillway part 4 of the gate are folded because they are made of flexible rubberized meliorative fabric. And when the gate is fully open, it automatically descends, being located on the bottom and walls of the channel (tray). Thus, ensuring the passage of water through the gate and maximally opening the cross-section of the channel. And when closed, this water-retaining gate automatically rises under hydrostatic water pressure and fills its tank with water. At the same time, increasing to the maximum size, completely overlapping the cross-section of the channel. The position of the autoregulator, filling, and emptying is adjusted automatically using the water level controller 5.

In this case, the mark of the top of the water level regulator pipe 5 is set at the mark of the required water level in the channel in front of the gate. In this case, water with a higher level mark than installed in the channel in front of the gate enters from the channel section in front of the automatic partition structure through the inlet 6 into the gate container and then into the pipe 7 and from it into the pipe 5 of the level regulator. Since the upper part of the level regulator pipe 5 is installed following the law of communicating vessels at a level equal to the water level in front of the partition structure, water flows out of the reservoir gate through the upper part of the pipe 5. After that, the water level in the reservoir of the gate of the automatic partition structure in the form of an autoregulator of the water level decreases and, consequently, the hydrostatic water pressure acting on the internal elements of the gate. This causes lowering, the opening of the gate and, consequently, an increase in water flow through the gate, as well as lowering the water level in the channel (tray) in front of the automatic partition structure to the level set in the channel. The principle of operation of the proposed automatic partition structure in the form of an autoregulator of the water level is as follows: in the absence of water in the channel (tray), the capacity of the gate 1 is empty, the spillway part 4 is located in the lower part of the gate 2. As water is supplied to the channel (tray) through the constantly open inlet 6 into the gate tank, the shutter tank 1 is filled with water; the shutter rises, increasing the water depth along the channel to the installation site of the partition structure. When the set level in front of the partition structure is exceeded, the water level in the reservoir of the gate 1, into which water enters through the inlet 6 from the channel to the installation site of the automatic partition structure, increases. Water from the reservoir of the gate 1 through the pipe 7 enters the water level regulator 5, made in the form of a pipe with an open top, and flows out of it into the part of the channel behind the gate since its top is set at a given water level mark in front of the gate. As a result, the amount of water entering the gate reservoir will be 3..4 times less than the amount of water flowing out of the gate reservoir; the gate reservoir 1 begins to empty, the spillway part 4 begins to descend, thereby increasing the flow of water discharged through the gate and lowering the water level in front of the automatic partition to a predetermined level. When the water level in the channel (tray) falls below the

set level in front of the automatic partition, water will not drain through the upper part of the water level regulator tube 5. Through the inlet 6, water will constantly flow into the reservoir of the gate but not flow out of the reservoir, the hydrostatic pressure inside the reservoir of the gate will increase, and the gate, filling with water, will begin to rise, blocking the section of the channel (tray) until the water level in the channel (tray) becomes higher than the mark set by the water level to the place of installation of the automatic partition. After that, water from the reservoir of the water-retaining gate begins to flow through the upper part of the water level regulator 5 into the part of the channel behind the gate.

Suppose the set water level is exceeded in front of the automatic baffle. In that case, the process is repeated until the water level is set, at which the amount of water entering the gate tank will equal the amount of water flowing out of the gate tank, corresponding to the set water level in front of the automatic baffle.

The proposed design of the automatic partition structure works completely on the hydraulic energy of the water flow. It automatically adjusts the water level along the channel (tray) length to the installation site of the automatic partition structure in the form of an autoregulator of the water level.

To determine the throughput of an automatic partition structure, which is an autoregulator of the water level with flexible working bodies for channels of parabolic cross-section (trays) of the irrigation system, its main element of a water-containing gate with flexible working bodies, experimental studies were conducted.

The model (Fig. 1, 2) consisted of a rigid spillway part 4, covered with elastic material made of rubberized reclamation fabric, passing into the pressure 3 and side parts 9 of the model, forming one whole with it and attached to a flatbed made of organic glass, made in the form of a box 2 0.358 m wide,  $L_2 = 0.64$  m long, with a height of 0.08 m in the middle part, installed at the bottom of the tray.

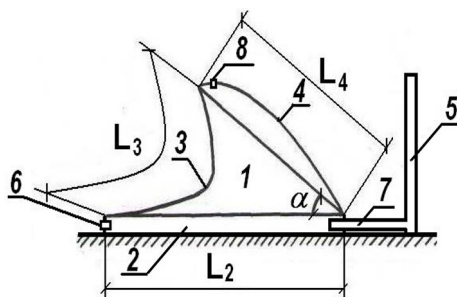

**Fig. 2.** Structural elements of model of water level autoregulator in longitudinal section for channels of parabolic cross-section (trays). (The side elements of the water-retaining gate of the water level autoregulator are not shown in the figure).

Modeling of the studied phenomena was carried out according to the criteria of gravitational similarity of Froude, the dynamic similarity of forces, similarity criterion of dynamic processes under the action of elastic forces (Cauchy criterion), described in the well-known work of P.G. Kiselev, A.D. Altshul, N.B. Danilchenko, A.A. Kasparson, G.I. Krivchenko, N.N. Pashkov, S.M. Slissky and the work of V.A. Prokofiev, G.A. Sudolsky [18], M.M. Balzannikov [19], A.V. Ostyakova, V.S. Borovkov [20], M.R. Bhajantri, T.I. Eldho, P.B. Deolalikar [21].

Modeling of the proposed design of the water level autoregulator was carried out by the method of physical modeling, using the criterion of geometric similarity of the model and nature at Reynolds numbers  $Re = 7145...56202 > Re_{kr} = 300$ , which corresponds to the

quadratic resistance region for open channels and Froude numbers  $Fr = 0.51...10.5$  with self-similarity of the phenomena under consideration.

Elastic material was modeled according to the maximum linear tension according to the recommendations of A.P. Nazarov. The scale of the model was adopted 1:2.

Studies of the flow capacity of the gate with flexible working bodies of the water level autoregulator were carried out on an experimental installation shown in Fig. 3.

The experimental setup consisted of a tray having a parabolic cross-sectional shape described by the equation  $x^2 = 0.4y$ . The length of the tray was 12 m, height - 0.4 m. The width of the tray in the upper part was 0.8 m. The maximum flow rate of water supplied to the tray was 0.0561 m<sup>3</sup>/s. The tray had a closed water supply system, which was supplied by a pump.

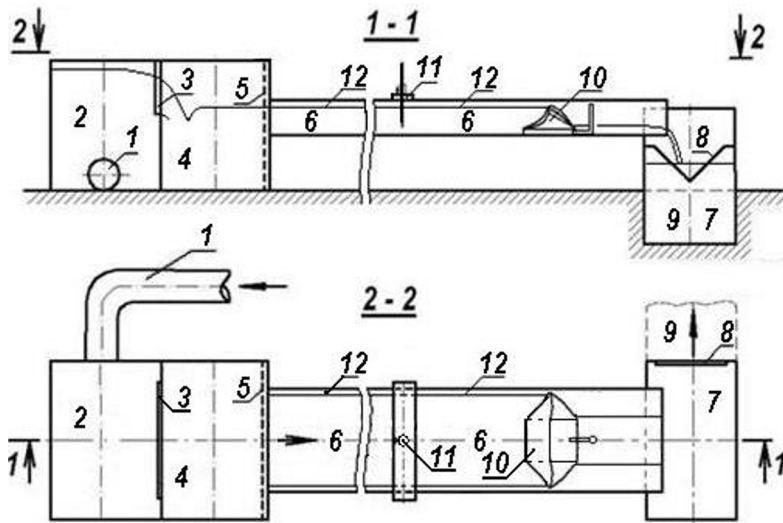

**Fig. 3.** Setup. 1 is pipe supplying water from pump, 2 is sedative tank No. 1, 3 is dimensional triangular spillway with thin wall, 4 is sedative tank No. 2, 5 is dampener of water flow energy in form of grid, 6 is tray, 7 is sedative tank No. 3, 8 is dimensional triangular spillway with thin wall, 9 is spillway trench, 10 is model under study, 11 is movable shelf with device installed on it for measuring water level in form of needle with measuring scale, 12 is water level in tray.

One model was studied with a rigid profile of the spillway part of the gate as a non-vacuum profile constructed according to the Krieger-Officer coordinates (Fig. 1, 2).

The main part of the experiment was carried out with a sequential increase in water consumption. The water flow rate in the pallet was measured using a measuring triangular spillway with a thin wall installed behind the pallet. All parameters were measured 15...20 minutes after changing the flow rate or any of the values.

### 3 Results and Discussion

During this time, an unchangeable feeding mode was set in the tray. In general, the flow coefficient is the following function

$$m = f(H, h_0 / H_z, \alpha, \alpha_{\max}, h_{vac} / H, \sigma_n, Fr, We, Re) \quad (1)$$

where  $H$  is the water pressure on the structure,  $h_0$  is the pressure above the spillway threshold, taking into account the velocity pressure,  $H_z$  is the height of the gate lift relative to the bottom of the channel in front of the structure,  $\alpha$  is the angle formed by the chord of the spillway part of the gate with a horizontal,  $\alpha_{max}$  is the maximum angle formed by the chord of the spillway part of the gate with a horizontal,  $h_{vac}$  is the vacuum pressure under the jet on the spillway part,  $\sigma_n$  is the coefficient taking into account flooding from the downstream side,  $Fr$  is the Froude number,  $We$  is the Weber number,  $Re$  is the Reynolds number.

It is almost impossible to consider the influence of all these parameters on the change in the flow coefficient. The calculation of the model's throughput was carried out according to a well-known formula:

$$Q = mb\sqrt{2g}h_0\sqrt{h_0} \quad (2)$$

where  $m$  is the flow coefficient,  $g$  is the acceleration of gravity or free fall, and  $b$  is the width of the spillway front.  $h_0$  is the head above the threshold of the spillway (the upper part of the gate), considering the high-speed head.

Because the speed in the tray was less than 1 m/s, the velocity head was a very small value; it was not taken into account,  $h_0$  was assumed to be equal

$$h_0 = (H - H_z) \quad (3)$$

where  $H$  is the depth of water in front of the partition structure,  $H_z$  is the lifting height of the shutter of the partition structure.

In this case, since the width of the spillway front of the structure is not the same in height because the channel has a parabolic section and is outlined along the parabola  $x^2 = 0,4 y$ , the width  $b$  was defined as

$$b = \sqrt{0.4H_z} + \sqrt{0.4H} \quad (4)$$

Therefore, formula (2) is converted to the following formula (5) to calculate the shutter capacity of the automatic partition

$$Q = m(\sqrt{0.4H_z} + \sqrt{0.4H})\sqrt{2g}(H - H_z)^{1,5} \quad (5)$$

During the research, the value of the flow coefficient  $m$  was determined based on the formula (5) as

$$m = Q_i / [(\sqrt{0.4H_z} + \sqrt{0.4H})\sqrt{2g}(H - H_z)^{1,5}] \quad (6)$$

where:  $Q_i$  is the water flow going through the way through the gate of the water level autoregulator.

Mathematical processing of the data of our research results of a water-retaining gate model with flexible working bodies and a rigid spillway part in the form of a non-vacuum profile at  $H_p = 0.15$  m, using the finite difference method, showed that the flow coefficient  $m$ , depending on the  $h/H_z$  ratio, varies according to the following parabolic dependence, figure 2.

$$m = -0.994(h/H_z)^2 - 0.5964(h/H_z) + 0.3505 \quad (7)$$

At  $h/H_z = 0.05 \dots 0.45$ , the flow coefficient varies within  $m = 0.37 \dots 0.45$ .

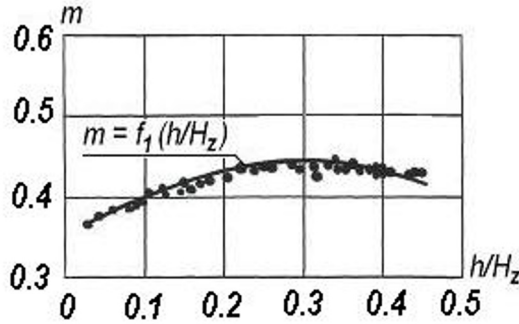

**Fig.4.** Graph of dependence  $m = f_1(h/H_z)$  obtained for water-containing gate with flexible working bodies and rigid spillway part in form of non-vacuum profile of automatic partition structure for channels of parabolic cross-section (trays) of irrigation system.

The obtained parabolic dependence (7) for determining the flow coefficient is consistent with the data of our experimental studies. At the same time, the difference between the values obtained by the formula and the experimental data was +4...5 percent. It can be seen from the graph in Fig. 4 that in the range of variation  $h/H_z = 0.05 \dots 0.45$ , the flow coefficient varies within  $m = 0.37 \dots 0.45$ .

Studies of the proposed design of the water level autoregulator for channels of parabolic cross-section have shown that it works steadily, without vibration; this proves the correctness of using the shape of its spillway part in the form of a non-vacuum, has sufficient accuracy of regulating a given water level within +5% in channels of the parabolic cross-section. Its throughput is determined by the formula (5); it does not narrow the working section of the channel, it is non-metal-intensive, made of cheap modern materials, and it can be made independently from improvised materials for various channels of parabolic cross-section (trays). It can be made in portable and stationary versions, is lightweight, transportable, can be transferred after watering from one place of the channel (tray) to another and installed by one or more workers, is easy to operate, works on hydraulic energy of the water flow, does not require electricity, is environmentally safe, has a cost of 5-7 times smaller than a conventional metal flap, combines the functions of stabilizing the required water level, dumping excess water, floating bodies and debris in front of the water level autoregulator, in fact, performs the function of an automatic partition structure for a channel (tray) of the parabolic cross-section.

## 4 Conclusions

Following the set goals and objectives: - the design of an autoregulator of the water level with flexible working bodies has been developed, which performs the function of an automatic partition structure for the channels of the parabolic section of irrigation systems (Fig. 1). It works stably and without vibrations since the shape of its spillway part was adopted without vacuum, - in the paper, a theoretical formula for determining the water flow through the gate of the water level autoregulator with flexible working bodies for channels of the parabolic cross-section is derived. - based on experimental studies, the



author has derived a formula for determining the flow coefficient  $m$ , which is included in the formula for the capacity of the water-retaining gate of the water level autoregulator, which is consistent with the data of our experimental studies within +4...5 percent and allows us to determine its throughput. - the proposed design of an autoregulator of the water level with flexible working bodies for channels of the parabolic cross-section of irrigation systems has sufficient accuracy of regulating a given water level in front of the autoregulator of the water level within +5%, does not narrow the working section of the channel, is not metal-intensive, lightweight, made of cheap modern materials, can be made independently from improvised materials. This can be done both in portable and stationary versions. At the end of watering, it can be moved from one place of the channel to another and installed by one or more workers, is easy to operate, works on the hydraulic energy of the water flow, does not require electricity, is environmentally friendly, has a cost 5...7 times lower than a conventional shutter. This design combines the functions of stabilizing the required water level, and dumping excess water, fin, and debris in front of the water level autoregulator. Therefore, it is recommended to use irrigation systems (trays) on channels of parabolic cross-section as an automatic partition structure.

## References

1. Ya.E. Pulatov. Vodoberegayushchie tekhnologii orosheniya i effektivnost' ispol'zovaniyavody v sel'skom khozyaystve. Journal Ekologiya I stroitel'stvo. Tajikistan, no. 4, pp. 21-26. (2017).
2. T.S. Koshkarova, L.N. Medvedeva, A.A. Novikov, L.A. Voyevodina. Organization of water accounting and water saving of irrigation water based on world experience in the conditions of changing climate. IOP Conference Series: Earth and Environmental Science, 14 Oct., vol. 577, iss. 1, article number: 012013. (2020).
3. V.N. Shchedrin, S.M. Vasiliev, A.A. Churaev. Kompleksnyy podkhod k otsenke pokoleniy orositel'nykh system na osnove sredstv imitatsionnogo modelirovaniya slozhnykh sistem. Izvestiya Nizhnevolzhskogo agrouniversitetskogo kompleksa: Nauka I vysshee professional'noe obrazovanie. Bull. of Nizhnevolzhsky Agro-University Complex: Science and Higher Professional Education, no. 4(32), pp. 189-193. (2013).
4. A.A. Aldoshkin. Kontseptsii neobkhodimosti razrabotki innovatsionnykh tekhnologiy stroitel'stva orositel'nykh sistem. Vestnik meliorativnoy nauki. Bulletin of Reclamation Science, no. 2, pp. 58-65. (2020).
5. E.M. Khalifa, M.A. Eltawil, M.E. Meleha, M.M. Sharaf. Enhancing the irrigation water management using developed irrigation canals. Journal of Soil Sciences and Agricultural Engineering, 34(6), 7481–7503. (2009).
6. P.P. Gadge, V. Jothiprakash, V.V. Bhosekar. Hydraulic design considerations for orifice spillways. ISH Journal of Hydraulic Engineering, 25(1), 12–18.(2019).
7. K.M. Melikhov, A.A. Pakhomov, N.A. Kolobanova. Vozmozhnost' avtomatizatsii podachi zadannogo raskhoda vody na otkrytykh orositel'nykh sistemakh. International Scientific Research Journal, no. 10(52), pp. 161-163. (2016).
8. V.N. Shchedrin, A.A.Churaev, V.M. Shkolnaya, L.V. Yuchenko. Simulation of dynamic management of water distribution at canals of open irrigation network. Nauchnyy Journal Rossiyskogo NII Problem Melioratsii, no. 4(20), pp. 1-20. (2015).
9. V.I. Olgarenko, N.S. Stepanova, O.P. Kisarov, I.V. Olgarenko. Matematicheskoe modelirovanie I issledovanie techeniy v Miussskoy orositel'noy sisteme na imitatsionnoy modeli. Izvestiya YUFU. Bull. YuFU, no. 6(131), pp. 52-56. (2012).

10. M.I. Balzannikov. Osnovnye metody sovershenstvovaniya konstruksij zatvorov gidrotekhnicheskikh sooruzhenij. News of Higher Educational Institutions. Construction. No. 12.Pp. 94-108. (2018).
11. T. Tomiyama, I. Nishizaki. Applicability of fiber reinforced plastics to hydraulic gates. In Composites in Civil Engineering, CICE 2006, pp. 453–456. International Institute for FRP in Construction (IIFC). (2020).
12. V.I. Loginov, S.M. Rtishchev, V.N. Kozyrev, M.V. Ilemenov, E.D. Mikhaylova. Evolopment and application of pre-erected hydraulic structures based on mobile water-filling dams to protect infrastructure in emergency situations associated with dangerous hydrological phenomena. Journal of Hydraulic engineering construction. The Ministry of Energy of the Russian Federation PJSC "RusHydro". No. 2., pp. 14-20. (2020)
13. M.-G. Kadirova. Hydraulic automatic regulator of level with flexible working bodies. Tashkent Institute of Irrigation and Agricultural Mechanization Engineers, E3S Web of Conferences 264, 03039 CONMECHYDRO – 2021. (2021).
14. M.-G. Kadirova. The shutter-automatic machine throughput of the washing device of the water level automatic regulator. Tashkent Institute of Irrigation and Agricultural Mechanization Engineers, E3S Web of Conferences 264, 03065 CONMECHYDRO – 2021(2021).
15. M.-G.A. Kadirova. Autoregulator of water level for tray channels of parabolic section. Journal "Hydraulic Engineering". No. 2 (June-August) / Project of The Media Group "Port News". ISSN 2227-8400. Science and Technology, pp. 26-31. (2022).
16. M.-G. A. Kadirova. Construction of a mobile dam to create a backup and automatic regulation of the water level on small rivers and watercourses in emergency situations. Proceedings of section No. 1 of the XXXII International Scientific and Practical Conference. Prevention. Salvation. Help. Khimki. Publishing house: Academy of Civil Protection of the Ministry of the Russian Federation for Civil Defense, Emergencies and Elimination of Consequences of Natural Disasters named after Lieutenant General D.I. Mikhailik (Khimki), pp: 49-53. (2022).
17. M.-G.A. Kadirova and F.A. Kadirov. A.S. No. 1588838 /USSR/. Autoregulator of the water level in the canal. Byull. Inventions. Moscow. 30.08. № 32.(1990).
18. V.A.Prokofev, G.A. Sudolskii. Hybrid modeling of hydrodynamics of spillway structures of hydroelectric power plants. Journal. Hydraulic engineering construction: Ministry of Energy of the Russian Federation PJSC "RusHydro". No. 8, pp. 60-66. (2021)
19. Mikhail Balzannikov. Studies of Structures of Gates in Hydraulic Engineering. 2019 IOP Conference Series: Materials Science and Engineering XXVIII R-P-S Seminar. 661. 012056 IOP. (2019)
20. A.V. Ostyakova, V.S. Borovkov. Analysis of the influence of the surface of the spillway with a plantar depression for spillways with a curved vacuum-free profile. Journal "Power Engineering and Mechanical Engineering", No. 48 (1), pp. 6-9. (2014)
21. M.R. Bhajantri, T.I. Eldho, P.B. Deolalikar. Numerical modelling of turbulent flow through spillway with gated operation. International journal for Numerical Methods and Fluids. First published: 14 February. (2007).