

Methods for solving mathematical Laplace equation for calculating transient process of short-term braking mode of traction electric motors (KTR TED) of diesel locomotive of TE10 type

*Utkir Safarov**, and *Nikolay Julenev*

Tashkent State Transport University, Tashkent, Uzbekistan

Abstract. In this article, ways to improve the device's efficiency for damping the field of a traction generator were considered. In the developed solution, containing a traction generator with an independent excitation winding, in parallel with which traction motors are switched on by power contacts that are switched off with a time delay, a power contact, switched from the first position from the controller, an excitation contactor, in the circuit of which the protection of the diesel generator set is connected in series, adjustable traction generator field damping resistance, connected in series in the conductive direction between the minus of the exciter and the traction generator field damping resistance, a diode, as well as excitation weakening contactors, switched on by the contacts of differential relays of the first and second stages for the current and voltage of the traction generator, connecting resistance power contacts parallel to the traction windings motors, and normally - open auxiliary contacts are connected parallel to the parts of the adjustable resistance to damping the field of the traction generator.

1 Introduction

This article considered ways to improve the traction generator field damping device's efficiency. In the developed solution, containing a traction generator with an independent excitation winding, in parallel with which traction motors are switched on by power contacts that are switched off with a time delay, a power contact, switched from the first position from the controller, an excitation contactor, in the circuit of which the protection of the diesel generator set is connected in series, adjustable traction generator field damping resistance, connected in series in the conductive direction between the minus of the exciter and the traction generator field damping resistance, a diode, as well as excitation weakening contactors, switched on by the contacts of differential relays of the first and second stages for the current and voltage of the traction generator, connecting resistance power contacts parallel to the traction windings motors, and normally - open auxiliary contacts are

*Corresponding author: utkirsafarov104@gmail.com

connected parallel to the parts of the adjustable resistance to damping the field of the traction generator.

Initial data:

- justification and drawing up the equivalent circuit of the power circuit for the calculation of transients;

- drawing up equations and solving them in a general form;

- analysis of the solution of equations.

Accepted assumptions:

- real TEDs are replaced by conditional ones [1]

- PC train contactors are on during the entire transition process;

- TEDs have the same electromechanical characteristics and winding parameters;

- magnetization curves of the traction generator and TED are linearized [1]

- the degree of weakening of the magnetic flux of all TEDs is the same and is determined by one resistor R_{sh} ;

- pretransition mode of locomotive operation at $t=0$ is stationary;

- the magnetic flux dissipation factor remains constant [1]

- switching the traction generator's excitation contactor is carried out instantly. This assumption does not distort the essence of the transient process under study, affecting only the initial values of the currents [2];

- the traction generator operates on emergency excitation.

Based on the assumptions made, the circuit in Figure 1.a corresponds to simultaneous, and circuit in Figure 1.b corresponds to non-simultaneous switching of the contact groups of the contactor VSH. The index "P" denotes the real, and the index "U" the conditional TED.

For simultaneous switching of contact groups, the parameters of the windings of the real and conditional TED:

$$R_{\partial y} = \frac{R_p}{n}; L_{\partial y} = \frac{L_p}{n} \quad (1)$$

Where $n=6$ - is the number of parallel branches of TED; R_p, L_p - - resistance and inductance of the corresponding winding of a real TED.

In the case of non-simultaneous switching, the "R" index corresponds to one TED, in which the contact group of the contactor VSH switches earlier than others and operates in the PP mode. The index "Y" denotes a conditional TED, replacing all the others, the contact groups of which have not yet been switched. The winding parameters of the conditional TED, in this case, are equal to:

$$R_{\partial y} = \frac{R_p}{n-1}; L_{\partial y} = \frac{L_p}{n-1} \quad (2)$$

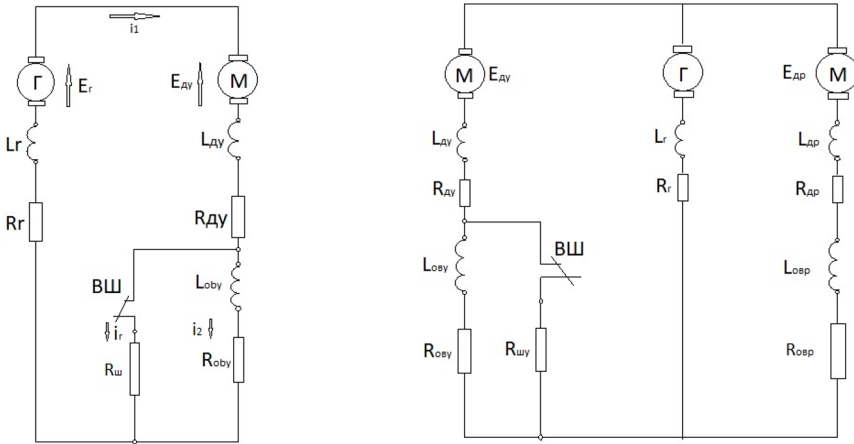

Fig. 1. Substitution schemes for the power of the circuit of diesel locomotives of the TE10 type when the excitation of the traction generator is turned off: a) with simultaneous switching of contact groups R; b) in case of non-simultaneous switching of contact groups R.

For the occurrence of CTE TED when the excitation of the traction generator is turned off, the following condition must be met:

$$\frac{d\Phi_{\Gamma}}{dt} > \frac{d\Phi_{\delta}}{dt} \quad (3)$$

which corresponds to a faster attenuation of the generator $U_{\Gamma}(t)$ voltage than the counter-emf of the TED. The laws of change $U_{\Gamma}(t)$ and $e_{\delta}(t)$ are taken exponential:

$$U_{\Gamma}(t) = U_0 e^{-\alpha_{\Gamma} t}; \quad e_{\delta}(t) = E_0 e^{-\alpha_{\delta} t}; \quad (4)$$

where U_0, E_0 are the voltage of the traction generator and the counter emf of the TED at $t=0^+$; $\alpha_{\Gamma}, \alpha_{\delta}$ are coefficients of attenuation of the generator voltage and counter emf of TED.

The possibility of adopting laws of change $U_{\Gamma}(t)$ and $e_{\delta}(t)$ verified as follows.

During the tests, the voltage of the traction generator and the counter-emf of the TED were oscillographed during the disconnection of the train contactors without time delay after the excitation of the traction generator was turned off.

The laws were checked using the "stretched thread" method [3] [35] Figure 2 shows graphs $U_{\Gamma}(t)$ and $e_{\delta}(t)$ and on semi-logarithmic paper with straight lines, which corresponds to the function $y = ae^x$.

Contactors VSH are switched on during the entire transient process of KTR TED. The studied transient process will be described by a linearized system of equations.

$$\begin{aligned}
 L_{\delta} \frac{di_1}{dt} + R_{\delta} i_1 + L_r \frac{di_1}{dt} + R_r i_1 + R_u i_3 &= U_r(t) - e_{\delta}(t); \\
 L_{o\delta} \frac{di_2}{dt} + R_{o\delta} i_2 - R_u i_3 &= 0; \\
 i_1 - i_2 - i_3 &= 0.
 \end{aligned}
 \tag{5}$$

Taking into account (2.4.), the system of equations (2.5.) can be written in the form:

$$\begin{aligned}
 L_{\delta} \frac{di_1}{dt} + R_{\delta} i_1 + L_r \frac{di_1}{dt} + R_r i_1 + R_u i_3 &= U_0 e^{-\alpha_r t} - e_0 e^{-\alpha_{\delta} t}; \\
 L_{o\delta} \frac{di_2}{dt} + R_{o\delta} i_2 - R_u i_3 &= 0; \\
 i_1 - i_2 - i_3 &= 0,
 \end{aligned}
 \tag{6}$$

Where i_1 is the current of the armature and additional poles (DP) of the TED; i_2 is excitation winding current of TEM; i_3 is current of the resistor shunting the OF TED; L_{δ} is armature inductance and DP TED; $L_{o\delta}$ is inductance of OV TED; L_r is inductance of the armature and DP of the traction generator; R_r is resistance of the armature and DP of the traction generator; R_u is resistance of the resistor shunting the OF TED.

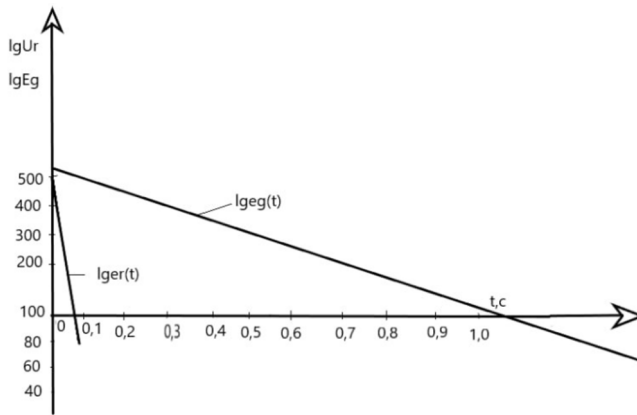

Fig. 2. Voltage attenuation of the traction generator and counter-emf of the TED operating in the OP mode of locomotives of the TE10 type

Image of the system of equations (6) according to Laplace [4]:

$$\begin{aligned}
 pL_{\delta} I_1(p) + R_{\delta} I_1(p) + pL_r I_1(p) + R_r I_1(p) + R_u I_3(p) &= \frac{U_0}{p + \alpha_r} - \frac{E_0}{p + \alpha_{\delta}} + L_{\delta} i_1(0) + L_r i(0) \\
 pL_{o\delta} I_2(p) + R_{o\delta} I_2(p) - R_u I_3(p) &= L_{o\delta} i_2(0); \\
 I_1(p) - I_2(p) - I_3(p) &= 0
 \end{aligned}
 \tag{7}$$

Compose the image of the armature current function $I_1(p)$:

$$I_1(p) = \frac{\mathcal{D}_1(p)}{\mathcal{D}(p)} \tag{8}$$

where: $\mathcal{D}_1(p)$ - determinant of the excitatory function; $\mathcal{D}(p)$ - determinant of the characteristic function.

Let's find expressions $\mathcal{D}(p)$ and $\mathcal{D}_1(p)$:

$$\mathcal{D}(p) = \begin{vmatrix} pL_\delta + R_\delta + pL_\Gamma + R_\Gamma; & 0; & R_u \\ 0; & pL_{oe} + R_{oe}; & -R_u \\ 1; & -1; & -1 \end{vmatrix} \tag{9}$$

Expanding the determinant $\mathcal{D}(p)$ equating it to zero, we obtain the characteristic equation $ap^2 + \beta p + c = 0$, where:

$$\begin{aligned} a &= L_{oe}(L_\delta + L_\Gamma) \\ \beta &= (L_\delta + L_\Gamma)(R_{oe} + R_u) + L_{oe}(R_\Gamma + R_\delta + R_u) \\ c &= R_{oe}(R_\Gamma + R_\delta + R_u) + R_u(R_\delta + R_\Gamma). \end{aligned} \tag{10}$$

Let's find the exciting function:

$$\mathcal{D}_1(p) = \begin{vmatrix} \frac{U_0}{p + \alpha_\Gamma} - \frac{E_0}{p + \alpha_\delta} + L_\delta i_1(0) + L_\Gamma i_1(0); & 0; & R_u \\ L_{oe} i_2(0); & pL_{oe} + R_{oe}; & -R_u \\ 0; & -1; & -1 \end{vmatrix} \tag{11}$$

Expanding the determinant gives:

$$\mathcal{D}_1(p) = i_1(0) \frac{Ap^3 + Bp^2 + Cp + D}{(p + \alpha_\Gamma)(p + \alpha_\delta)} \tag{12}$$

where $A = L_{oe}(L_\delta + L_\Gamma)$;

$$\begin{aligned} B &= \left[L_{oe} \frac{U_0 - E_0}{i_1(0)} + (L_\delta + L_\Gamma)(R_{oe} + R_u + \alpha_\Gamma L_{oe} + \alpha_\delta L_{oe} + R_u L_{oe} \beta) \right]; \\ C &= \left[(R_{oe} + R_u) \left(\frac{U_0 - E_0}{i_1(0)} \right) + L_{oe} \left(\frac{\alpha_\delta U_0 - \alpha_\Gamma E_0}{i_1(0)} \right) + (L_\delta + L_\Gamma)(\alpha_\delta + \alpha_\Gamma)(R_{oe} + R_u) + (\alpha_\delta + \alpha_\Gamma)L_{oe}R_u\beta + \right. \\ &\quad \left. + \alpha_\delta \alpha_\Gamma (L_\delta + L_\Gamma)L_{oe} \right]; \\ D &= \left[(R_{oe} + R_u) \frac{\alpha_\delta U_0 - \alpha_\Gamma E_0}{i_1(0)} + \alpha_\delta \alpha_\Gamma (\alpha_\delta + \alpha_\Gamma)(R_{oe} + R_u) + \alpha_\delta \alpha_\Gamma R_u L_{oe} \beta \right]; \beta = \frac{i_2(0)}{i_1(0)}. \end{aligned}$$

The image of the current $I_1(p)$ taking into account (10) and (11) and the equality in them $A=a$.

$$I_1(P) = \frac{P^3 + \frac{B}{A}P^2 + \frac{C}{A}P + \frac{D}{A}}{(P^2 + \frac{B}{A}P + \frac{C}{a})(P + \alpha_r)(P + \alpha_d)} \quad (13)$$

Let us determine the parameters of the windings of the traction generator and the TED to calculate the roots of the characteristic equation (10) as applied to a diesel locomotive of the TE10 type.

The inductance of the L_{oe} TED is determined from the magnetization curve of the TED from the equation:

$$L_{oe} = \frac{d\Phi}{di}.$$

The inductance of the armature windings of the traction generator and TED is determined by the formula [6]:

$$L_{я} = 0.6 \cdot \frac{U_{nom}}{p \cdot \omega_{nom} \cdot I_{nom}} \quad (14)$$

The inductance of the DC is determined by the formula [7]:

$$L_{\partial n} = 0.65 \cdot 2\sigma_{\kappa} p \Phi_{\kappa} \frac{\omega_{\partial}}{i_{я}} \quad (15)$$

Conditional TED inductance L_{∂}

$$L_{\partial} = \frac{L_{яТЭД} + L_{\partial nТЭД}}{6} = 0.53 \cdot 10^{-3} \Gamma \quad (16)$$

The inductance L_{Γ} traction generator:

$$L_{\Gamma} = L_{я\Gamma} + L_{\partial n\Gamma} = 0.963 \cdot 10^{-3} \Gamma \quad (17)$$

The value of the resistance R_{∂} , R_{Γ} , R_{uu} conditional TED we will accept according to [8].

$$\begin{aligned} R_{\Gamma} &= 2.185 \cdot 10^{-3} \text{Om}; & R_{\partial} &= 3.52 \cdot 10^{-3} \text{Om}; \\ R_{uu}^{O\Gamma 1} &= 3.283 \cdot 10^{-3} \text{Om}; & R_{uu}^{O\Gamma 2} &= 1.533 \cdot 10^{-3} \text{Om}. \end{aligned} \quad (18)$$

Substituting the values of the parameters of the windings of the traction generator and TED in (10), we obtain:

$$\begin{aligned} \alpha_1^{O\Gamma 1} &= -1.402c^{-1}; & \alpha_2^{O\Gamma 1} &= -6.667c^{-1} \\ \alpha_1^{O\Gamma 2} &= -1.057c^{-1}; & \alpha_2^{O\Gamma 2} &= -4.605c^{-1} \end{aligned} \quad (19)$$

Formula (13) of the current image $I_1(p)$ taking into account (19), we rewrite in the form:

$$I_1(p) = \frac{p^3 + \frac{B}{A}p^2 + \frac{C}{A}p + \frac{D}{A}}{(p + \alpha_1)(p + \alpha_2)(p + \alpha_r)(p + \alpha_\delta)}. \quad (20)$$

In the transition from the image of the current $I_1(p)$ to the original $i_1(t)$ we use here and below the formula:

$$Z^{-1}\left(\frac{M(p)}{N(p)}\right) = \sum_{k=1}^q \frac{M(p_k)}{N(p_k)} e^{p_k t}, \quad t \geq 0 \quad (21)$$

Where: $\frac{M(p)}{N(p)}$ is rational fraction with simple poles p_k ($k = 1, 2, \dots, q$)

p_k is root of the equation $N(p) = 0$

The original current $i_1(t)$ will look like this:

$$i_1(t) = \alpha^{-1} \left[i_1(0) \frac{p^3 + \frac{B}{A}p^2 + \frac{C}{A}p + \frac{D}{A}}{(p + \alpha_1)(p + \alpha_2)(p + \alpha_r)(p + \alpha_\delta)} \right] = \quad (22)$$

$$= (k_1 e^{-\alpha_1 t} + k_2 e^{-\alpha_2 t} + k_3 e^{-\alpha_r t} + k_4 e^{-\alpha_\delta t}) \cdot i_1(0)$$

where:

$$k_1 = \frac{(-\alpha_1)^3 + \frac{B}{A}(-\alpha_1)^2 + \frac{C}{A}(-\alpha_1) + \frac{D}{A}}{(-\alpha_1 + \alpha_2)(-\alpha_1 + \alpha_r)(-\alpha_1 + \alpha_\delta)};$$

$$k_2 = \frac{(-\alpha_2)^3 + \frac{B}{A}(-\alpha_2)^2 + \frac{C}{A}(-\alpha_2) + \frac{D}{A}}{(-\alpha_2 + \alpha_1)(-\alpha_2 + \alpha_r)(-\alpha_2 + \alpha_\delta)};$$

$$k_3 = \frac{(-\alpha_r)^3 + \frac{B}{A}(-\alpha_r)^2 + \frac{C}{A}(-\alpha_r) + \frac{D}{A}}{(-\alpha_r + \alpha_1)(-\alpha_r + \alpha_2) \cdot (-\alpha_r + \alpha_\delta)};$$

$$k_4 = \frac{(-\alpha_\delta)^3 + \frac{B}{A}(-\alpha_\delta)^2 + \frac{C}{A}(-\alpha_\delta) + \frac{D}{A}}{(-\alpha_\delta + \alpha_1)(-\alpha_\delta + \alpha_2)(-\alpha_\delta + \alpha_r)};$$

The solution consists of four exponents decreasing in time t .

Taking expression (22) to zero and solving it concerning time t , we find the moment when the current $i_1(t)$ passes through zero:

$$i_1(0)(k_1e^{-\alpha_1 t} + k_2e^{-\alpha_2 t} + k_3e^{-\alpha_r t} + k_4e^{-\alpha_\delta t}) = 0 \quad (23)$$

Where

$$k_1e^{-\alpha_1 t} + k_2e^{-\alpha_2 t} + k_3e^{-\alpha_r t} + k_4e^{-\alpha_\delta t} = 0 \quad (24)$$

As a result of the logarithm, we get:

$$\ln k_1 - \alpha_1 t + \ln k_2 - \alpha_2 t + \ln k_3 - \alpha_r t + \ln k_4 - \alpha_\delta t = 0$$

or

$$\ln k_1 + \ln k_2 + \ln k_3 + \ln k_4 = t(\alpha_1 + \alpha_2 + \alpha_r + \alpha_\delta) \quad (25)$$

The final expression for the time t , at which $i_1(t)$ the current passes through zero is

$$t = \frac{\ln(k_1 k_2 k_3 k_4)}{\alpha_1 + \alpha_2 + \alpha_r + \alpha_\delta} \quad (26)$$

The maximum reverse current amplitude is determined if the derivative of expression (22) is set equal to zero:

$$\frac{di_1}{dt} = i_1(0)(-k_1\alpha_1 e^{-\alpha_1 t} - k_2\alpha_2 e^{-\alpha_2 t} - k_3\alpha_r e^{-\alpha_r t} - k_4\alpha_\delta e^{-\alpha_\delta t}) = 0 \quad (27)$$

Where

$$-k_1\alpha_1 e^{-\alpha_1 t} - k_2\alpha_2 e^{-\alpha_2 t} - k_3\alpha_r e^{-\alpha_r t} - k_4\alpha_\delta e^{-\alpha_\delta t} = 0 \quad (28)$$

As a result of the logarithm, we get:

$$-\ln k_1 + \ln \alpha_1 - \alpha_1 t - \ln k_2 + \ln \alpha_2 - \alpha_2 t - \ln k_3 + \ln \alpha_r - \alpha_r t - \ln k_4 + \ln \alpha_\delta - \alpha_\delta t = 0 \quad (29)$$

The time t , at which the current $i_1(t)$ reaches its maximum value is:

$$t = \frac{\ln(\alpha_1 \alpha_2 \alpha_r \alpha_\delta)}{\alpha_1 + \alpha_2 + \alpha_r + \alpha_\delta} = \frac{\ln(k_1 k_2 k_3 k_4)}{(\alpha_1 + \alpha_2 + \alpha_r + \alpha_\delta) \ln(\alpha_1 \alpha_2 \alpha_r \alpha_\delta)} \quad (30)$$

The maximum reverse current amplitude in relative units is:

$$i_{1\max} = k_1\alpha_1 e^{-\alpha_1 t} + k_2\alpha_2 e^{-\alpha_2 t} + k_3\alpha_r e^{-\alpha_r t} + k_4\alpha_\delta e^{-\alpha_\delta t} \quad (31)$$

With the simultaneous disconnection of the contact groups of the contactor R, the equivalent circuit shown in Figure 1.a is valid, in which the non-linear arc resistance is switched on in series with the resistor RSH. The expression for the current $i_1(t)$ with a linearized arc characteristic will look like:

$$i_1(t) = i_1(0) \left[k_1 e^{-\alpha_1 t} + k_2 e^{-\alpha_2 t} + k_3 e^{-\alpha_3 t} + k_4 e^{-\alpha_4 t} \right] + i_1'(0) \left[k_1' e^{-\alpha_1' t} + k_2' e^{-\alpha_2' t} + k_3' e^{-\alpha_3' t} + k_4' e^{-\alpha_4' t} \right] \quad (32)$$

where, $k_1' \div k_4'$, $\alpha_1' \div \alpha_4'$ are coefficients that differ from the previous ones in that during their operation, the value of the resistor R is increased by the value of the linearized arc resistance; $k_1 \div k_4$, $\alpha_1 \div \alpha_4$ coefficients having the same values as in equation (22); $i_1(0)$ is the initial value of the current before switching the contactor R.

2 Conclusion

The burning of the arc before the transition of the current of the armature of the TED to the region of negative values, on the contacts of the VSH, following the value of the dynamic resistance of the arc R_d , reduces the value of the armature current in the region of negative values and accelerates (within the arc burning) the flow of the transient. This was implemented in circuit solutions of the sequence of switching contactors in the circuit diagrams for controlling contactors of diesel locomotives of the TE10 type.

References

1. Djanikulov A.T. Modeling of dynamic phenomena in the mechanisms of starting diesel main locomotives.p. 21. (2006)
2. Dzhanikulov A. T. Methodology and results of computational investigations to establish the current functions of the power circuit when starting the diesel generator. Universum: Engineering Sciences, (5-4(98)), pp. 30-33. (2022).
3. V.N. Zhidkov, A.H. Gaziev. Some transients in the energy chain of TE10 locomotives. Bulletin of Tashkent Institute of Railway Engineers, No 88. (1977).
4. Klinachev N.V., Voronin S.G. Simulation of the process of starting an internal combustion engine with an electric starter. Journal "Bulletin of South Ural State University. Series "Power Engineering", Vol. 15, pp. 49-56. (2015).
5. Romanov V.I. To calculation of coefficient of dynamism taking into account gaps in vertical transmission at start of diesels of type 10D100. Bulletin of Tashkent Institute of Railway Engineers, No 5(157). (1975).
6. Anikeev I.P., Kornev A.N. Improved scheme of the condenser system of diesel start-up. The journal Locomotive, No.4, pp. 29. (2000).
7. Kasimov O. T., Djanikulov A. T., and Mamayev S. I. Modeling the bending of the tire surface by pads during braking. In AIP Conference Proceedings, Vol. 2402, No. 1, p. 070030. (2021).
8. Djanikulov A. T., Mamayev S. I., and Kasimov O. T. Modeling of rotational oscillations in a diesel locomotive wheel-motor block. In Journal of Physics: Conference Series, Vol. 1889, No. 2, p. 022017. (2021).

9. Kasimov O., Fayzibayev S., Djanikulov A., and Mamayev S. Numerical studies for estimation of temperature fields in bandage material during locomotive braking. In AIP Conference Proceedings, Vol. 2432, No. 1, p. 030025. (2022).
10. Valiev M., and Kosimov K. Diagnosing the technical condition of the diesel cylinder-piston group. In E3S Web of Conferences, Vol. 264, p. 04061. (2021).
11. Yusupov D. T., Kutbidinov O. M., Samadov S. A., and Abdullaev E. S. Investigation of winding faults of traction transformers. In IOP Conference Series: Earth and Environmental Science, Vol. 868, No. 1, p. 012026. (2021).
12. Ablyalimov O., Khamidov O., and Domanov K. Determination of Locomotive Traction Efficiency on the Section of Marokand-Kattakurgan of Uzbek Railway. In Networked Control Systems for Connected and Automated Vehicles: Vol. 1 (pp. 671-680). Cham: Springer International Publishing. (2022).
13. Khamidov O., and Udalova D. Technical and Economic Efficiency of Intelligent Data Analysis on the Railways of the Uzbekistan Republic. In International Scientific Siberian Transport Forum TransSiberia-2021: Volume 1 (pp. 230-239). Cham: Springer International Publishing. (2022).
14. Khamidov O. R., and Grishchenko A. V. Locomotive asynchronous traction motor rolling bearing fault detection based on current intelligent methods. In Journal of Physics: Conference Series, Vol. 2131, No. 4, p. 042084. (2021).
15. Grishchenko A. V., Kruchek V. A., Kurilkin D.N., and Khamidov O.R. Diagnostics of the technical condition of rolling bearings of asynchronous traction motors of locomotives based on data mining. Russian Electrical Engineering, Vol. 91, pp. 593-596. (2020).
16. Ablyalimov O., Petrochenko S., and Kodirov N. Analyzing the Movement of a Freight Train at Stops on Flat Sections of the Railway. In Networked Control Systems for Connected and Automated Vehicles: Vol. 2 (pp. 165-171). Cham: Springer International Publishing. (2022).