

# Dynamic models and analysis of overflow of upper level of GTS for their automatic protection

A.M. Usmanov, D.B. Yadgarova, A.M. Nig'matov

"Tashkent Institute of Irrigation and Agricultural Mechanization Engineers" National Research University

**Abstract.** A catastrophic increase in the supply channels of hydraulic structures on canals should be controlled, and automatic headwater protection from overflow should be carried out. Knowing the dynamic model of such a process, it is possible, according to a previously developed algorithm, to generate a control signal at the beginning of the transient process to prevent an emergency. The reasons were analyzed as threats leading to the overflow of the headwater, among which non-discharged sediments stably intensify the dynamics of the transition process. A control system simulation model was created in the MatLab environment, the coefficients were determined, and the dynamic characteristics of the pool overflow process were built. In this case, the time constant was 7 seconds, and the removal of the control signal was possible within 1-3 seconds after the start of the transition. Reducing the probability of a pool overflow threat is predicted to be within 25%.

## 1 Introduction

The functioning of hydraulic structures on irrigation canals must be protected from threats associated with the possibility of emergency events. They may be caused by operating imperfections, technical problems, or natural causes. Such threats include increased water consumption, uncontrolled and undischarged sediments on the GTS, local rainfall, jamming of gates, and violation of the rules for operating the GTS equipment. [4]. Therefore, the automatic protection of structures based on emergency and pre-emergency situations at hydraulic structures is an urgent task.

From a technological point of view, the research object is the headwater of the GTS on the channel. It is characterized as an object for controlling the water load in the inlet channel of the GTS in the form of a generally reduced coordinate  $h$  - the water level upstream. It is known that very diverse loads and forces act on hydraulic structures, which differ in impact, origin, duration, and frequency [4]. By origin and physical nature, forces and loads include incl. impact of sediment deposited upstream of the structure. The slopes of the free surface, the flow velocity, and, consequently, the transporting capacity of the flow going upstream to the blocking structure decrease as it approaches the hydroelectric complex, resulting in sediments entrained by the flow partially settling to the bottom [4]. On the GTS of the canals, such sediments are not controlled, or they are controlled with interrupted periodicity using bottle meters and laboratory non-expressive methods.

## 2 Methods and solutions

This approach turns sediments into a threat to the GTS, along with increased water consumption, heavy rainfall, and gate jamming. In this case, the standard situation, Fig. 1, is not presented as a threat in view of the distribution of events for the GTS over time.

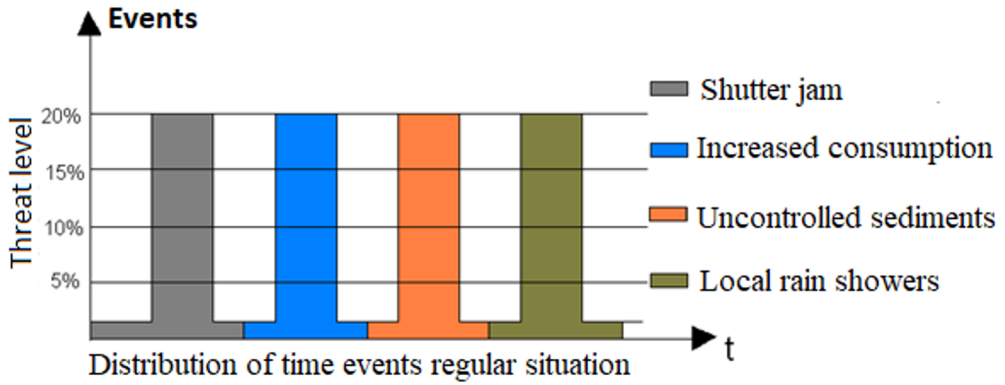

Figure 1. Diagram of events on GTS distributed over time

However, the occurrence of an emergency is associated with the superposition of all the above events in a single period, Fig. 2. The formulation of such an approach opens up the following possibilities for analysis:

1. Is it possible to eliminate the threat of increased consumption? This is impossible. Since a pass, for example, transit costs cannot be canceled.
2. It is also impossible to exclude (local) heavy rainfall.
3. It is possible to exclude gate jamming, but this technical issue is superimposed by the human factor of production operation in which a particular gate is located. And this really cannot eliminate the threat of jamming.
4. Is it possible to exclude the threat from sediments? This is a solvable issue, for which it is necessary to control them and manage the process of removing (discharging) sediments by promptly opening the discharge gate. However, this is not enough. The threat of flooding is significantly reduced by 20-25%, but this takes time since the rise in the level upstream occurs much faster than the capabilities of the mechanical part of the HTS gates.

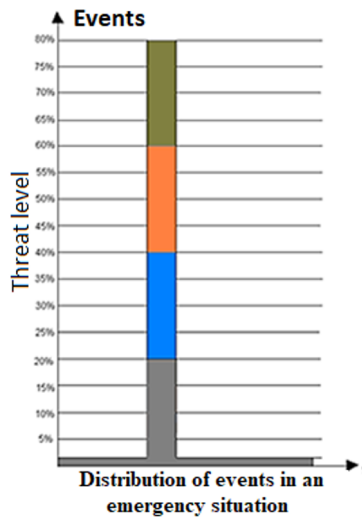

Fig.2. Diagram of events concentrated in time

Figure 2. Diagram of events concentrated in time.

### 3 Dynamic characteristics of the object.

The analysis of the possibilities of an emergency made it possible to establish the need to know:

- the nature of the level change in the upper pool, its dynamics, and the intensity of this process;
- to form on this basis a warning signal about an approaching accident;
- know about the change in the state of sediments at hydraulic structures, as well as the level of these sediments, since it affects the overall water level in the pool;
- creating an automatic control system (ACS) for the level and pumps at the GTS.

Dynamic models for controlling the level of the headwater of hydraulic structures on the canal are presented by well-known authors [5,6,7]. These models were considered from the point of view of "stabilizing the levels of the headwaters" under disturbing influences caused by the outlet outlets [6]. In general, the equation in the images of the water level deviation in the upper pool has the form [5]:

$$Z = \frac{L_1 p + K}{T_1 p + 1} \frac{\gamma_1}{\kappa_2} N_H A_H \exp(-\tau_1^1 p) \quad (1)$$

where:

$L_1$  is characterization of initial conditions

$T_1$  is time constant of the element of the control system

$N_H$  is coefficient reflecting the influence of the elements (shutter) of the system management

$\frac{\gamma_1}{\kappa_2}$  is an indicator characterizing the conditions of the outflow of water

$K$  is object transfer coefficient

In this equation, one can single out an elementary link with a fractional-irrational transfer function

$$\frac{L_1 p + K}{T_1 p + 1} \quad (2)$$

which is connected in series with the inertialess link

$$\frac{\gamma_1}{\kappa_2} N_H A_H$$

and a link of pure delay

$$\exp(-\tau_1^1 p) \quad (3)$$

Although the sensor is installed upstream, there is a certain delay in the inlet channel at the beginning of the transient process due to the significant accumulation indicators upstream.

It should be said that the dynamic representations of the process are based on the transformation of nonlinear Saint-Venant equations to linear equations in partial derivatives, which makes it possible to apply the provisions of linear automatic control systems [6,10,13]. This made it possible in the experimental part of the work with the physical model of the structure to remove some acceleration curves with different intensities of the level rise in the upper pool, Fig.3.

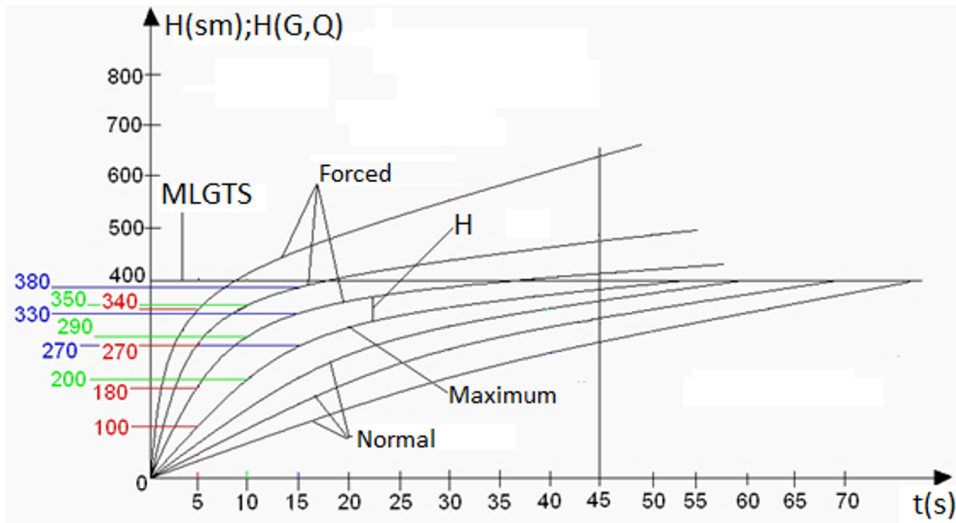

**Figure 3.** Family of experimental dynamic characteristics.

Taking into account the process of water accumulation in the HTS bowl during a possible emergency, as in the control object, and the results of experimental indicators, as well as the work of the authors [5,6], it was decided: to establish the object as a dynamic process of an aperiodic link with a delay

$$W(p) = \frac{K}{T_1s + 1} \cdot e^{-st} \tag{4}$$

where coefficients:

- time constant of the object, information indicator of the intensity of water inflow into the GTS;
- pure delay of the process in the object; Room for the equation.
- the transfer coefficient of the object.

As you can see, the dynamic performance indicators of the forced mode differ significantly from the "maximum" and "normal" modes. Their acceleration is carried out in almost 15-20 seconds.

These models served as the basis for developing a functional diagram of the automatic control system to implement operational reset. Based on this and the given dynamic models, a block diagram of the process control was compiled, and a simulation model of the automatic control system was compiled in the environment of the MATLAB SIMULINK subsystem, fig. 4.

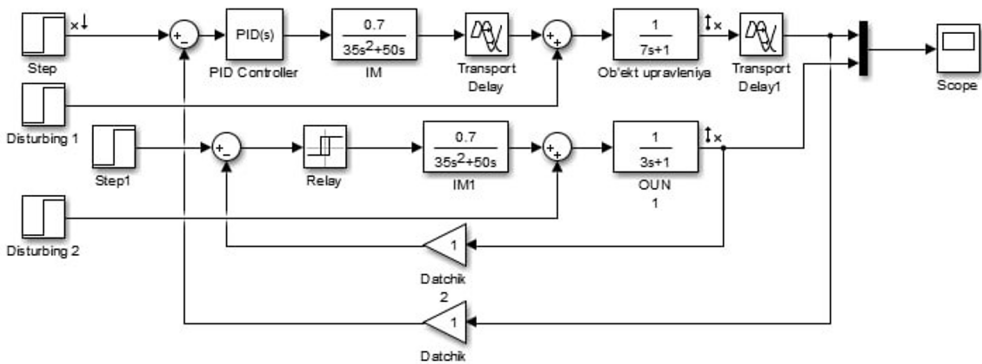

**Figure 4.** Simulation model of level control in V.B. GTS

The study of the control system on a simulation model also pursued the goal of preparing materials for creating an electronic bank of hydraulic structures models with sediment galleries, coastal discharges, etc., which will significantly increase the efficiency of automatic operational protection of structures. In this case, the authors got acquainted and used the experience of operating the Karman facilities on the river. Zarafshan, Navoi region.

The control system structurally looks like Fig. 4. The transfer function of the object will be written as:

$$P(s) = \frac{K}{s(T_s s + 1)}$$

To measure the level in the upper pool, a sensor is used, the mathematical model of which is written as an aperiodic link of the first order (In this model, the time constant is very small, and the desired value can be taken as 1.)

$$H(s) = \frac{K}{T_{oc}s + 1}$$

The linear model of the drive (actuator) is an integrating link with a transfer function

$$R(s) = \frac{1}{T_R s + 1}$$

In the automatic control system, a PID is used as a controller - the controller whose model is

$$C(s) = K_c \left( 1 + \frac{T_s}{T_v s + 1} \right) + \frac{1}{T_i s}$$

When building a simulation model, the features of the technological process of control were taken into account. They were associated with the need to include inter-vessel connections of the sediment control loop in the water level control system.

To clarify this thesis, the oscillograms were processed following the intended purpose of the work. Namely, to remove the signal, as shown in Fig. 5, 2 seconds after the start of the transient process, points a and b. If the acceleration curve passes through these points, then this dynamic characteristic corresponds to the emergency state of the HTS. Therefore, along the sediment control loop (Fig. 4), it is necessary to influence the actuator (model of the integrating link). In the technological control object, it is necessary to discharge sediments.

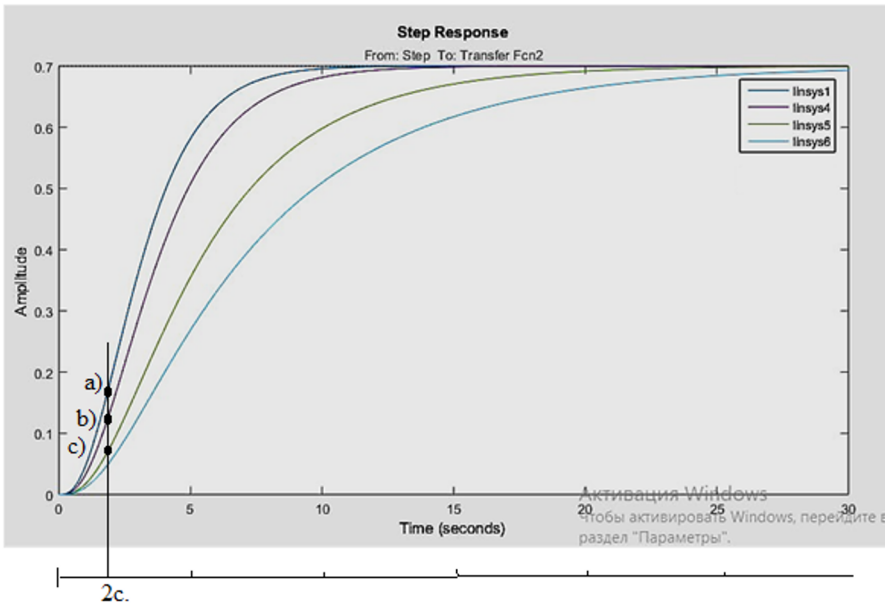

Figure 5. Dynamic characteristics of level intensity

## 4 Conclusions

Emergency overflows of the upper pools can be caused by the reasons for the passage of increased flow rates through the channel, the uncontrolled state of sediments and their untimely discharge, locally heavy rains, and jamming of gates in the lower position. In a normal, regular mode, these threats are distributed in time, and the occurrence of an accident can be prevented by the established measures. The emergency state is associated with the imposition of the threats mentioned above in a single period. Monitoring the dynamics of the rise in the headwater level and the state of sediments makes it possible to establish the pattern of emergency filling of the headwater, for which a simulation model was built in the MatLab environment, and dynamic models of the process were obtained. It was an aperiodic link of the 1st order with a delay. On this basis, it was possible to realize the assumption that if, at the beginning of the transient process, a parameter characterizing a sharp change in the level of the upper pool is measured over a certain period, then, using the known dynamic model of the transient process, it is possible to set the value of the output signal, which will show an emergency (catastrophic) level after completion of the transient and create a pre-emptive signal to raise the gates in time for a reset. The results were characterized by receiving a signal after 1-3 seconds after the start of the transient process for an object with a time constant  $T = 7$  sec. And the recommendations for automatic sediment release made it possible to reduce the threat of flooding hydraulic structures by 25%.

## REFERENCES

1. Kotyuk A.F. *Datchiki v sovremennyh izmereniyah.*(KotyukA.F. Sensors in modern measurements.) Moscow 2006. 225p.
2. Usmanov, A., Nigmatov, A., & Azizova, N. (2023). Technologies and means of protection in process of managing pumping stations. Paper presented at the E3S Web of Conferences, , 365 doi:10.1051/e3sconf/202336504015 Retrieved from [www.scopus.com](http://www.scopus.com)
3. Gazieva, R., Aynakulov, S., Ozodov, E., & Nigmatov, A. (2019). Automatic diffusion mixing system for watering in regions with high water sales. Paper presented at the International Conference on Information Science and Communications Technologies: Applications, Trends and Opportunities, ICISCT 2019, doi:10.1109/ICISCT47635.2019.9011841 Retrieved from [www.scopus.com](http://www.scopus.com)
4. Ubaydulayeva, S., Gazieva, R., & Nigmatov, A. (2020). Calculation of dynamic processes in relay systems of automatic control based on graph models. Paper presented at the IOP Conference Series: Materials Science and Engineering, , 883(1) doi:10.1088/1757-899X/883/1/012152 Retrieved from [www.scopus.com](http://www.scopus.com)
5. Ubaydulayeva, S. R., & Nigmatov, A. M. (2020). Development of a graph model and algorithm to analyze the dynamics of a linear system with delay. Paper presented at the Proceedings - 2020 International Conference on Industrial Engineering, Applications and Manufacturing, ICIEAM 2020, doi:10.1109/ICIEAM48468.2020.9111939 Retrieved from [www.scopus.com](http://www.scopus.com)
6. Begimov I. *Automation of canals in the Ferghana Valley.* SIC ICWC. T. 2010.
7. Rozhnov V.A., Tyumenev R.M. Electrical systems for stabilizing water levels in canals. – F.: Ilim, 1982.
8. Rozanov N.P. *"Hydraulic structures"* M. Agropromizdat, 1985.
9. Makovsky E.E., *Automation of hydraulic structures in systems of cascade regulation of water flow rates.* Frunze" ILIM" .1972.
10. Ra'no, G., Shaxnoza, U., Sherqul, R., Barno, R., Aziz, N., & Aziz, A. (2020). Automatic restart of the pumping unit and control circuit with one button. Journal of Critical Reviews, 7(5), 337-339. doi:10.31838/jcr.07.05.66
11. Usmanov A.M., Nigmatov A.M., *"Transient processes of gate control system elements in sediment discharge automation."*<< AGRO ILM.>> 1(33)-son, 2015.
12. Ubaydulayeva, S., Nigmatov, A., Yunusova, S., & Eshmatova, B. (2023). Automated monitoring system for assessment of the current state of groundwater. Paper presented at the AIP Conference Proceedings, , 2612 doi:10.1063/5.0118280 Retrieved from [www.scopus.com](http://www.scopus.com)
13. Gazieva, R., Aynakulov, S., Ozodov, E., & Nigmatov, A. (2019). Automatic diffusion mixing system for watering in regions with high water sales. Paper presented at the International Conference on Information

Science and Communications Technologies: Applications, Trends and Opportunities, ICISCT 2019,  
doi:10.1109/ICISCT47635.2019.9011841 Retrieved from [www.scopus.com](http://www.scopus.com)