

Experimental tests of submersible vane pumps

*Oleg Glovatskii*¹, *Rustam Ergashev*², *Naira Nasirova*¹, *Jaloliddin Rashidov*^{2*} and *Boybek Kholbutaev*³

¹Research University of Irrigation and Water Problems, Tashkent, Uzbekistan

²"Tashkent Institute of Irrigation and Agricultural Mechanization Engineers" National research University, Tashkent, Uzbekistan

³Jizzakh polytechnical institute, Jizzakh, Uzbekistan

Abstract. The technical task of creating new designs of submersible vane pumps is to maintain stable operating parameters and increase the productivity of the pumping station with periodic regeneration and sediment removal. The pumping well station contains an outer chamber and an inner chamber, in which a pumping unit is installed, and pipelines are connected to the lower and upper pools. In the structure under study, the upper parts of the outer and inner chambers are equipped with a sealed head, and the lower part of the outer chamber is equipped with a stopper. The side surface of the inner chamber is made of elastically deformable material. An elastic pipeline with an ejector at its end with curvilinear helical grooves on the inner surface of the nozzle part of the ejector is connected to the pipeline connected to the tailpipe, and water level meters are installed in the outer chamber. The technique of balance testing of new designs of submersible vane pumps was applied because the existing technology is insufficient for correct balance tests. Research methods involve the design of the impeller, which is rigidly mounted on the shaft. The methodology has been adjusted to apply to multistage pumps with different types of impellers. In the energy balance of this pump, the power losses due to friction in the individual axial support of the impeller are additionally determined. Experimental work was carried out, resulting in measurements of the hydrodynamic moment acting on the guide vane grate. Experimental work was carried out on a vertical stand with new pump impellers ETsV-10-120-40 and with a service life of 1 year. Parametric tests made it possible to determine the change in the external parameters of the pump depending on changes in its operating conditions and network characteristics.

1 Introduction

Given the importance of determining the characteristics of submersible vane pumps to improve its technical level and efficiency, in the past, experiments were carried out to compile a complete energy balance in a centrifugal pump based on experimental data [1,2].

*Corresponding author: jaloliddin5@mail.ru

Based on the work done with single-stage ground centrifugal pumps, a technique was established for determining the energy balance in a centrifugal pump, which is still used by many engineers and researchers [3,4]. Subsequently, this technique was adjusted for application to multistage pumps [5,6]. But it is not sufficient to determine the characteristics of a submersible vane pump for the tasks of the described studies.

2 Materials and Methods

To use the new vane pump, it is sufficient to have a pump performance curve consisting of curves of the head, power consumption, and efficiency versus volumetric flow reduced to a constant speed. According to these parameters, it is approximately possible to determine the technical level of the pump. But these parameters are not enough to choose ways to increase this level, for which it is necessary to know the internal characteristics of the pump: the division of energy losses into separate components of the speed moments after the impeller and the guide vane [7, 8].

Research methods suggest the execution of the impeller, which is rigidly mounted on the shaft. In the energy balance of the pump, the power losses due to friction in the individual axial support of the impeller are additionally determined. At the same time, leakage through the impeller seal is practically eliminated in operating modes in which the impeller is in its lower position. The technique applies only to single-stage pumps with a zero circumferential component at the impeller inlet. Based on the above reasons, experimental work was carried out to determine the internal characteristics and energy balance of submersible vane pumps, as a result of which two methodologies were obtained.

The first method of balance testing of pumps is a modernization of S.S. Rudnev's method, considering losses due to hydraulic resistance [9, 19]. Losses are divided into three parts: mechanical losses, consisting of friction losses in the seal along the sleeve, disk friction losses, hydraulic resistance losses, and volume loss. When listing the loss components, the authors omitted volumetric losses since these losses are insignificant and are practically compensated by the restored part of the disk friction.

The methodology for carrying out balance tests of the ETsV-10-120-40 pump was developed at a stage consisting of a cast-iron guide vane and a bronze impeller. The surfaces of the flow channels of the wheel were ground to a roughness of $R_z \approx 5 \mu\text{m}$. The surface roughness of the flow channels of the cast guide vane corresponded mainly to $R_z = 60 \mu\text{m}$. The gaps on the wheel seal were 0.32 mm per diameter, and on the bushing - 0.15 mm per diameter. Experimental work was carried out on a vertical stand.

3 Results

By design, a submersible pump is a monoblock unit with a built-in electric motor located in a sealed housing in the water flow mainly from the side of the suction part of the unit [4,10]. In the lower part of the electric motor, possible leaks are collected through the shaft seals in the unit housing. The leaked water is removed from there by increasing the air pressure in the engine cavity by supplying it from the compressor.

ETsV brand pumps are single or multistage submersible centrifugal vertical pumps with one-way inlet impellers. The ETsV electric pump consists of a pump, a submersible motor, a power cable, a water-lifting pipeline, wellhead equipment, and an automatic control system. The pump bearings are lubricated and water-cooled.

Experimental work was carried out on a vertical stand with new pump impellers ETsV-10-120-40 and impellers with a service life of 1 year (Fig. 1)

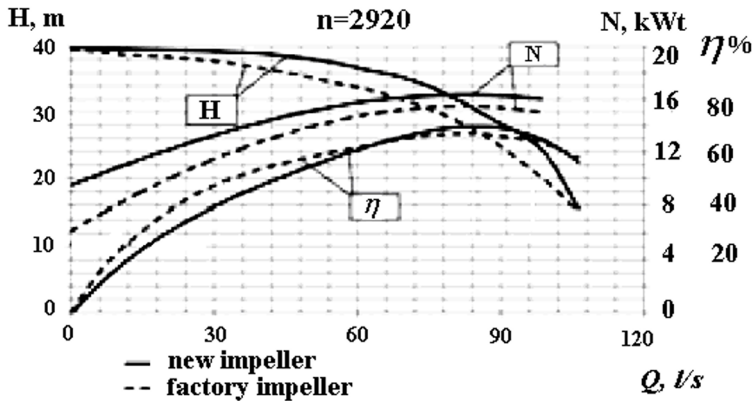

Fig. 1. Determination of pressure and energy characteristics pump ETsV-10-120-40

When calculating pumping stations equipped with pumps of the ETsV type, additional pressure losses in the water-lifting pipes of the pumps were taken into account in the amount of 3...6% of the pump head. Parametric tests make it possible to determine the change in the external parameters of the pump depending on the change in its operating conditions and network characteristics [11, 12].

Life tests determine the actual reliability, durability, and maintainability of the tested pump.

Research tests were carried out with the main goal - to improve various indicators of the pump: efficiency, reliability, and increase in resources. The new designs' technical task is to maintain stable operating parameters and increase the productivity of pumping stations (PS) with sequential stage pumps with axial and centrifugal impellers.

Experimental values were determined based on measurements of pressure and energy characteristics according to the method described in the literature [7, 13].

The run-in of the assembly with impellers was carried out until at least 80% of the washer area was in contact with the thrust bearings.

The result is achieved by the fact that in the PS, containing the outer and inner chamber, in which the pump unit is installed, pipelines connected to the downstream and upstream pools, to which an elastic pipeline is connected with an ejector at its end with curved helical grooves on the inner surface of the ejector. The authors used this design for horizontal pumps [14,15].

Fig. 2 shows a diagram of the PS with a scan of the inner surface of the nozzle part of the ejector with curved helical grooves.

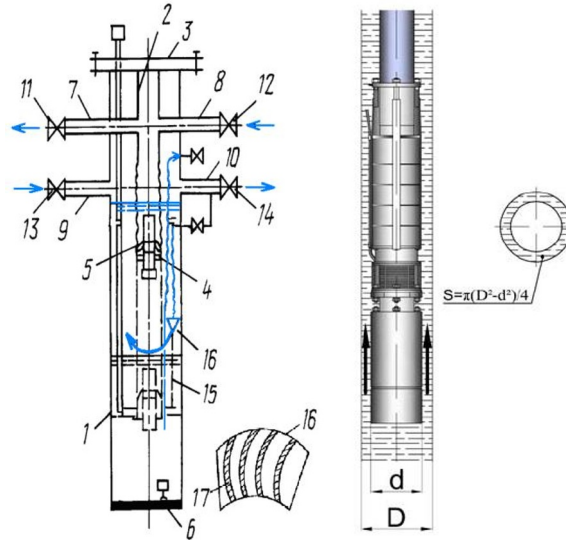

Fig. 2. Scheme of submersible pump with scan of inner surface nozzle part of ejector

PS consists of outer 1 and inner 2 chambers, the upper end of each of which is provided with a sealed head 3. The inner chamber 2 is made with a flange 4 to install the pumping unit 5. The side wall of the inner chamber 2 is made of elastically deformable material, such as corrugated rubber. The outer chamber 1 has a plug 6 in the lower part. The inner chamber 2 (injection zone) is connected the downstream by pipeline 7, and the upstream by pipelines 8, 9, and 10. Pipelines 7...10 are equipped with gates 11...14, respectively. To the pipeline 10, to the gate 14 is connected to the elastic pipeline 15 with the ejector 16 at its end with curvilinear helical grooves 17 on the inner surface of its nozzle part.

With a high water level in the outer chamber 1, the inner chamber 2 is in a compressed state, and the pump unit 5 is located in the upper position. When the pump unit 5 is turned on, water is pumped from the suction zone between chambers 1 and 2 into the inner chamber 2. An excess pressure arises in the inner chamber 2, contributing to its expansion, and the pump unit 5 is immersed under the water level when the latter decreases. When the pump unit 5 is turned off, the pumping of water stops, and the pressure in the inner chamber 2 decreases, raising the pump unit 5 to its initial position.

With the accumulation of sediment in the outer chamber 1, the ejector 16 is switched on, which, moving along the inner surface of the outer chamber 1, washes off the colmatant with the help of a stream of water, leaving the nozzle part of the ejector 16 in a swirling form, having sufficient hydrodynamic, centrifugal and vibrational forces in curved helical grooves.

Timely removal of the bridging agent and accumulated sediment from the outer chamber helps maintain stable hydraulic parameters and, combined with additional circulation in the pump unit, increases its performance.

Installing a pump with a smaller diameter relative to the diameter of the well leads to a significant decrease in the flow rate that cools the electric motor and, as a result, to its overheating and reduced resource.

The required diameter is selected based on the condition: the fluid velocity U must be at least 0.2 m/s [10, 12].

Depending on the required flow, the diameter of the pump is selected:

$$d \geq \sqrt{D^2 - \frac{4 \cdot (Q/3600)}{\pi \cdot v}} \quad (1)$$

where: D is well diameter, m; d is pump diameter, m.

Using swirling and circulation improves the hydraulic parameters of the water supply to the pump and increases its suction capacity. When it is impossible to provide a speed of at least 0.2 m/s, it is necessary to use a special cooling casing for the pump motor [16,17].

During testing, friction losses N_ζ and along the length N_l are determined. The disc friction losses N_d were obtained from the difference in the measured sum of losses.

Efficiency is determined by the formulas:

Volumetric efficiency

$$\eta_w = \frac{Q}{Q + q_{\text{leak}}} \quad (2)$$

Hydraulic efficiency

$$\eta_h = \frac{H}{H_{\text{th}}} \quad (3)$$

Mechanical efficiency

$$\eta_m = \frac{N_{\text{th}}}{N_{\text{spent}}} \quad (4)$$

The dependences of volumetric, hydraulic, and mechanical efficiency found as a result of experiments are shown in Fig. 3.

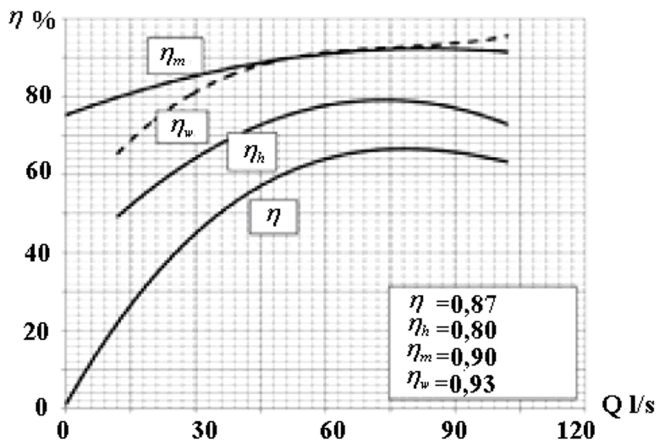

Fig. 3. Efficiency with new impeller combinations

The design with new combinations of axial and centrifugal impellers has virtually no leakage through the impeller seal. To determine impeller seal leaks and inter-stage seal

leaks, appropriate holes were drilled in both stage assemblies to measure the pressure drop across these seals. The theoretical head of a stage with a centrifugal wheel will be greater than that of a stage with an axial wheel per leakage component in the seal gap.

After completion of the test, the measuring steps were interchanged, and the experiment was repeated. When testing with new combinations of impellers, the order of changing the operating modes of the assembly from a closed valve (mode 1) to an open one (mode 2) was observed.

Volumetric losses in the interstage seal of the stage turned out to be insignificant; in the optimal mode, they are equal to 0.61% of the consumed power. Considering that the recovered part of the disk friction has a value of the same order, the difference between the losses in the interstage seal and the power recovered from the disk friction will be small.

The friction losses N_ζ in the impeller and inter-stage seals were determined by measuring the power consumed by the stage emptied of water but with the stand shaft seal collar filled with water. According to the difference of the measured sum of losses, disk friction losses were obtained. The theoretical head of the steps is N_d .

$$H_{th} = \frac{N_{th}}{\rho g(Q + q)} \quad (5)$$

$$N_{est} = N_{th} - (N_\zeta + N_d) \quad (6)$$

The characteristic of the indicated modes with H_{T1} and H_{T2} is shown in Fig.4.

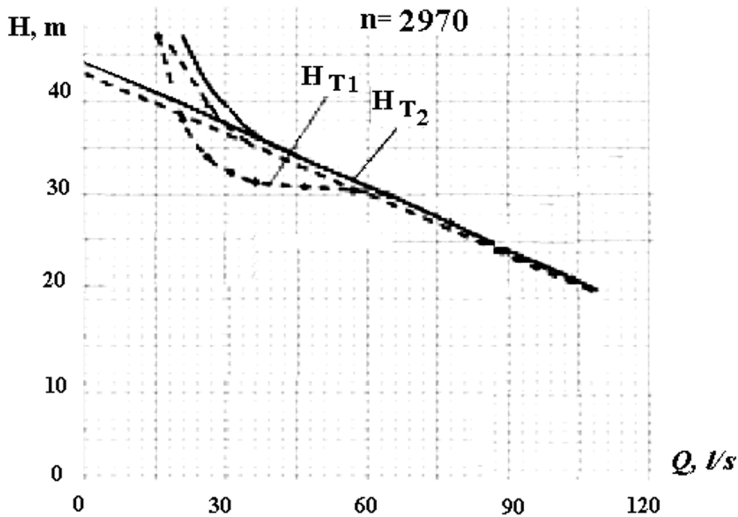

Fig. 4. Theoretical heads of impellers in various modes

Laboratory experiments allowed drawing up balances of power spent on hydraulic resistance N_h and leakage N_{leak} .

$$N_h = Q\rho g(H_T - H) \quad (7)$$

$$N_{\text{leak}} = q\rho gH \quad (8)$$

The found power losses are shown in Fig.5.

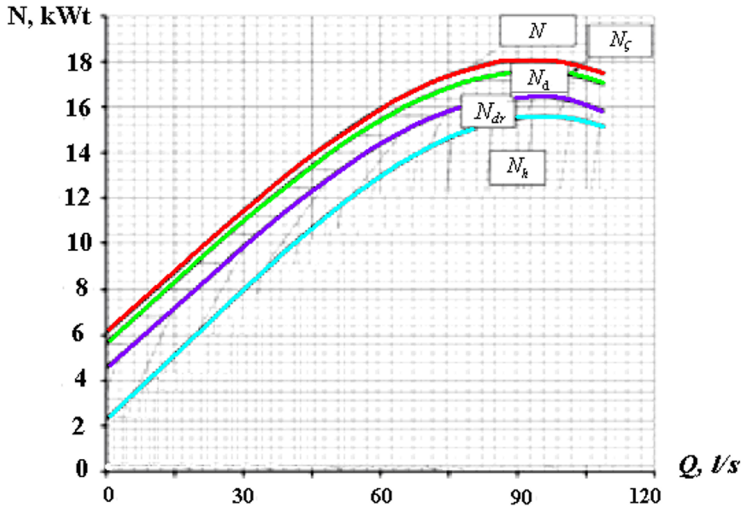

Fig. 5. Power loss

The method for determining the energy balance of a stage is based mainly on measurements of the hydrodynamic moment acting on the guide vane grate (G_{vg}) with radial blades (plates) located at the outlet of the guide vane when a liquid flow passes through them, determined by the weighing method.

The essence of the method is based on the interaction of the flow with the grating of the guide vane. In this case, the guide vane experiences a certain hydrodynamic moment relative to its central axis [5]:

$$M = \rho \frac{Q}{2\pi} (G_{\text{imp}} - G_{\text{vg}}) H_m \quad (9)$$

where Q is the flow rate passing through the guide vane, m^3/s ; G_{imp} and G_{vg} are, respectively, the average values of the circulation at the outlet of the impellers and at the outlet of the grate of the guide vane, m^2/s

The measured dynamic moment makes it possible to determine the theoretical head of a stage with a floating impeller:

$$H_{\text{th}} = \frac{\omega}{2\pi g} (G_{\text{imp}} - G_{\text{vg}}) \quad (10)$$

$$H_{\text{th}} = \frac{\omega M}{\rho g q} \quad (11)$$

The moment acting on the apparatus was measured by the tensometric method, where the grate of the guide apparatus was mounted on a rolling bearing, and the moment acting on the apparatus was transferred to a plate rigidly connected to it with glued strain gauges (Figure 6).

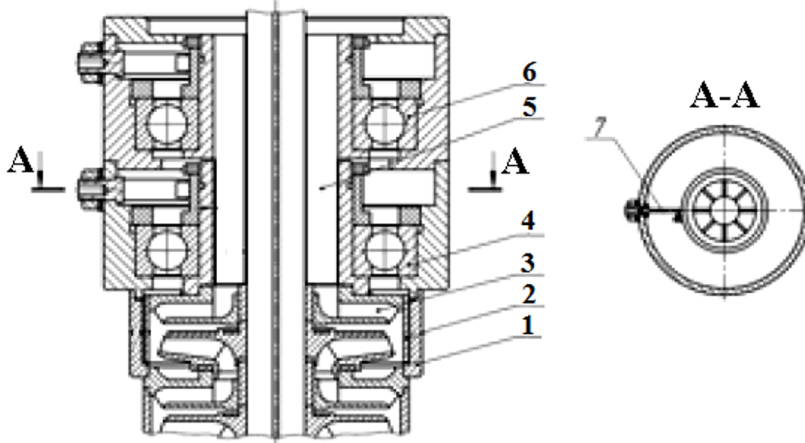

Fig. 6. Flow measurement device: 1 is fixed clip; 2 is movable clip; 3 is guide apparatus; 4,6 are bearings; 5 is measuring grid; 7 is load cells

Pulses from strain gauges are transmitted to strain gauge equipment. Load cells are pre-calibrated. Based on the measured hydrodynamic moment, it is possible to determine the average value of the circulation at the outlet of the guide vane at each feed

$$G_{\text{vg}} = \frac{2\pi}{\rho} \cdot \frac{M}{Q} \quad (12)$$

Based on the measured average flow circulation at the outlet of the guide vane, the H'_{th} component is determined at zero flow circulation at the impeller inlet

$$H'_{\text{th}} = \frac{\omega G_{\text{vg}}}{2\pi g} \quad (13)$$

The described method for determining the energy balance of the stage is also applicable for stages fixed on the impeller shaft when determining volumetric leaks along the seals of the impellers and along the sleeve and determining friction losses by a known method.

An analysis of the operation of submersible vane pumps and the causes of failures allows us to conclude that of all the factors that determine the service life of pumps, the greatest influence is exerted by cavitation-hydroabrasive wear of the impellers.

Experiments show that with an increase in hydroabrasive wear of the impellers, significant dynamic loads appear associated with the imbalance of the drive shaft due to low-frequency vibrations perceived by the bearing units. These factors lead to a decrease in the pressure generated by the pump.

Practice shows that the pump requires a major overhaul when the pressure drops to 0.75 of the theoretical value ($0.75 N_{\text{th}}$). The resource of impellers for various pump operating conditions does not exceed 480-500 hours of continuous operation. Under the conditions of constant changes in the operating modes of the pumping station, volumes, concentration, and physical and mechanical characteristics of the flow, which significantly affect the wear rate of the pump elements, the main methods are inaccurate.

Known designs of the PS in which pumping units of various types are installed, pipelines connected to the lower and upper pools by several pipelines and the upper parts of

the outer and inner chambers are equipped with sealed heads, and the lower parts are made of flexible material with plugs [4,5]. The disadvantage of these elements of the PS is the difficulty in operation.

In other PS, the walls of the chambers are made of an elastically deformable material, and the adjustable pump contains guide planes parallel to the axis of the suction pipe with an elastic surface [6,7].

The disadvantages of these PS are the possibility of reducing their performance as sediment accumulates in the outer chamber, the formation of a colmatant on its inner surface, and the inability to control the position of the pumping unit.

4 Conclusions

1. Parametric tests of submersible vane pumps are of the greatest interest to reclamation specialists since their results are necessary not only to assess the possibility of using a pump of one brand or another under given conditions but also to analyze the operation of the entire hydraulic network in which the pump is installed. The results of these studies are presented in the article as generalized graphs of H , N , η during operation.

2. Parametric tests made it possible to determine the change in pump parameters depending on changes in its operating conditions and network characteristics. The order of changing operating modes was followed during bench tests with new combinations of impellers. The theoretical head of the steps is determined. An experimental characteristic is given for the specified modes with volumetric, hydraulic, and mechanical efficiency dependences.

3. The technique for determining the stage energy balance described in the article was used for stages with impellers fixed on the shaft when determining volumetric leaks and friction losses. The disc friction losses were obtained from the difference in the measured sum of losses. Of all the factors that determine the life of pumps, the greatest influence is exerted by cavitation-hydroabrasive wear of impellers during parallel operation [18, 20].

References

1. Alexandrov V.I., Menshikov C.C. Coefficient of technical state of the slurry pumps. Natural and technical sciences. Vol. 4, pp.66-71. (2014).
2. Aleksandrov V. I., and Avksentiev S. Y. Vibration-based diagnostics of slurry pump technical state. Indian J. Sci. Technol, Vol.9, pp.1-6. (2016).
3. Beglov I. F., and Glovatsky O. Y. Analysis of fault diagnosis systems for pumping units. In Presented at the. (2001).
4. Chebaevsky V. F., Vishnevsky K. P., and Nakladov N. N. Design of pumping stations and testing of pumping units. Moscow: Kolos. (2000).
5. Glovatskiy O., Ergashev R., Rashidov J., Nasyrova N., and Kholbutaev B. Experimental and theoretical studies of pumps of irrigation pumping stations. In E3S Web of Conferences, Vol. 263, p. 02030. (2021).
6. Ikramov N., Majidov T., Kan E., and Akhunov D. The height of the pumping unit suction pipe inlet relative to the riverbed bottom. In IOP Conference Series: Materials Science and Engineering, Vol. 1030, p. 012125. (2021).
7. Bazarov D. R., Norkulov B. E., Kurbanov A. I., Jamolov, F. N., and Jumabayeva, G. U. Improving methods of increasing reliability without dam water intake. In AIP Conference Proceedings, Vol. 2612, (2023).
8. Bazarov D., Krutov A., Sahakian A., Vokhidov O., Raimov K., and Raimova I.

- Numerical models to forecast water quality. In AIP Conference Proceedings, Vol. 2612, pp. 020001. (2023).
9. Burlachenko A. V., Chernykh O. N., Khanov N. V., and Bazarov D. R. Damping of increased turbulence beyond a deep and relatively short spillway basin. In AIP Conference Proceedings, Vol. 2612, (2023).
 10. Menon E. S. Working Guide to Pump and Pumping Stations: Calculations and Simulations. Gulf Professional Publishing. (2009).
 11. Bakhriddin K., Azam A., and Alisher D. Full-scale testing of water intake pumps of pumping stations. In E3S Web of Conferences, Vol. 97, p. 05017. (2019).
 12. Kramarenko V.V., Savichev O.G. Hydraulics. Part I. Tomsk, (2009).
 13. Angus R. W. Testing Motor-Driven Pumps. Journal (American Water Works Association), 32(5), 838-844. (1940).
 14. Patent RUz. FAP 00528 "Shrub protection device for water intake", MKI E 02 B 5/00.
 15. Patent RUz. FAP 01069 "Device for supplying liquid at the pump inlet", MKI F 04 D 15/02.
 16. Patent of England No. 1414 163 "Cleaning device". National class E01H 1/10, IPC E1.
 17. RF patent 2164579 "Pumping stations", MKI E 03 B 5/00.
 18. Olszewski P. Genetic optimization and experimental verification of complex parallel pumping station with centrifugal pumps. Applied Energy, Vol. 178, pp.527-539. (2016).
 19. Varley F. A. Effects of impeller design and surface roughness on the performance of centrifugal pumps. Proceedings of the Institution of Mechanical Engineers, Vol.175(1), pp. 955-989. (1961).
 20. Glovatskiy O., Khamdamov B., Sidiqova M. Q., and Raxmonova N. A. Environmental aspects of energy saving modes of hydropower facilities. Web of Scientist: International Scientific Research Journal, Vol. 3(02), pp. 809-820. (2022).