

Development of the management system of technical indications of high-power charger-discharger rectifier device

*Khasan Murodov**, and *Askarbek Karshibayev*

Navoi State University of Mining and Technologies, Navoi, 210100, Uzbekistan

Abstract. Uninterruptible power supply devices are the main sources of operational DC power supply to control devices and control devices. In addition, the charge-discharge rectifier devices in thermal power plants and substations are autonomous operational current sources of power plants and substations. This source is the main constant and alternating current source for relay protection devices, telecommunication devices, control and monitoring devices in power stations and substations. As switching devices, the most commonly used ones today are thyristor, controlled by the thyristor control electrode. It is possible to control the charging and discharging processes of the batteries. In this case, random charging or discharging of the battery will reduce its service life. Therefore, this article examines its management system. Today's high-power uninterruptible power supply rectifier devices show that stations and substations are not ready for emergency situations due to their unstable operation and inability to control the state of the battery. Therefore, the improvement of this device remains the major issue.

1 Introduction

The reliable operation of the energy system serves to fundamentally improve the infrastructure of the regions, establish new networks, and ensure continuity and stability of production processes [1].

Currently, the power generation capacity is increasing. In Uzbekistan, the construction and operation of steam-gas thermal power plants of new generations of thermal power plants has accelerated. In 2012, the first steam-gas thermal power plant with a capacity of 478 MW was built and commissioned in Navoi region. This thermal power plant has inspired the construction of other such steam-gas plants to this day due to its efficient power supply and natural gas economy. An example of this is the construction of a 450 MW steam-gas plant in Navoi region in 2019, and it is planned to create 2 more 650 MW steam-gas thermal power plants by the end of 2024 [2].

The role of the charge-discharge rectifier devices of the 1st BGQ plant in Naoi region, which is operating today, is important in the production of electricity and thermal electricity. Through this device, all automatic devices, control and control devices, measuring devices,

* Corresponding author: murodov.xasan@inbox.ru

accumulator batteries in the station are supplied with electric energy. Some devices at the station, which have been in operation for more than 10 years, are morally and materially worn out and need to be replaced with modern, cost-effective devices. One of them showed the failure of the control and control system of the charge-discharge rectifier devices, the inability to control the batteries, and the unpreparedness for emergency situations. It is necessary to monitor and diagnose the condition of each battery. The battery management system used at the station needed to be further simplified and improved. For this, it is necessary to study the control devices of thyristor batteries and make new solutions. By improving the microprocessor control board and the control device, the opening of thyristors, the charging and discharging process is controlled.

AC to DC conversion is widely used in many industries and manufacturing. In this case, it is very important in charging batteries, in electrolysis processes, in providing constant current motors, in providing electric current to various types of electronic devices.

Rectifier devices are devices that convert alternating current into direct current. The main devices of the rectifier devices are the transformer, valve blocks and electric smoothing filters. A transformer is used to step down the AC voltage to the load. Valve blocks perform the function of one-way voltage transfer, that is, correction, and are the element that performs the main work. Filters reduce the pulsation of the rectified voltage and bring the voltage harmonics closer to their average value.

Valve blocks are made by using a set of one or more rectifier diodes and thyristors. In this case, they are divided into one-and-a-half-cycle and two-and-a-half-cycle rectifiers. According to the phase, it is used as single-phase, three-phase and multi-phase. Depending on the rectification of alternating voltage, the number of phases to be rectified, the nature and requirements of the load, the current and voltage required by the load, electric valves are connected in various circuits [6].

According to the consumed load power, in devices with electric valves up to 15 W, a single-phase one-half-cycle rectifier circuit or a midpoint single-phase rectifier is used. For loads from 15 W to 300 W, single-phase two-and-a-half-cycle rectifier devices are used, and for higher-power loads, three-phase one-and-a-half-cycle and three-phase two-and-a-half-cycle rectifiers are used [5].

Thermal power stations Navoi branch 478 MW steam-gas workshop is used for charging the accumulator batteries in low load mode. In this case, the power consumed by the consumer is 5-6 kW, while the battery batteries can provide a maximum power of 176 kW [3].

Control of the charge-discharge process of battery batteries a control it is necessary to take into account several parameters of it: these are I_{max} , I_{nor} , DOD_{max} , U_{char} , I_{char} – operating mode parameters, UC_0 , E_0 , R_{in} , K_i – functional state parameters, U , I , DOD , SOC , T – current state parameters, T_0 , p , ξ – external conditions, τ – time, C_0 , U_0 , I_p – factory nominal parameters. Battery simulation parameters: C_0 , U_0 – rated capacity and voltage; I_p – maximum current strength value; I_{max} , $I_{нор}$ – maximum allowable and normal discharge current; DOD_{max} – permissible discharge depth; U_{char} , I_{char} – recommended charging voltage and current; R_{in} – internal active and polarizing resistance; R_{in} – electric capacitance; E_0 – chain separator voltage; SOC – charge level; T_0 , p , ξ – ambient temperature, pressure, humidity [7].)

2 Materials and methods

The research was carried out using a systematic approach, regression analysis and experimental theoretical planning methods. A power plant consists of a number of devices that work interdependently. Therefore, the systematic approach plays an important role in the

description of complex systems. When charging and discharging accumulator batteries, it is more convenient to use the regression analysis method to describe the function of changing its charging parameters depending on time by mathematical expectation and to find the optimal solution. Also, a theoretical plan of the researched object is made as an experiment to see the general state of the battery management and control system.

Accurate time control is an important role in ensuring stable operation of accumulator batteries. In this case, the charge or discharge capacity of the accumulator batteries is integrally dependent on the current over time:

$$C_{\text{char}(\text{dischar})} = \int_0^t I_{\text{char}(\text{dischar})}(t)dt,$$

Here $C_{\text{char}(\text{dischar})}$ is the charge or discharge capacity of the battery

3 Results

When determining and controlling the technical parameters of the battery, the following parameters are checked, which are important: charge, discharge current and voltages, and also its charge and discharge levels, control of external environment temperatures. For Bunig, Matlab checked the parameters in the charging process of the Battery Battery in Simulink.

The main element of uninterruptible power supply devices is to prevent deep discharge by regulating the process of charging and discharging batteries, which requires control and management of their technical parameters.

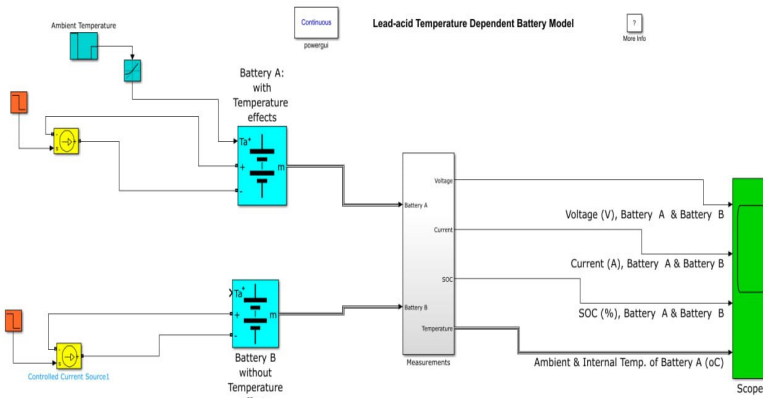

Fig. 1. Control of the technical parameters of high-power lead acid battery batteries.

Protective devices need to be supplied from an autonomous power supply source because the electrical voltage coming out of the generator changes its value by pulsing the voltage in it which reduces the measurement accuracy of the measuring devices. In addition, many of the electrical control sensors are also supplied with constant current through battery batteries. In this case, the power supply from the external electrical network, that is, also from the energy system, the non-stability of the voltage in it cannot ensure the operation of all measurement, control, control devices, therefore, if the battery batteries provide through 110 volts the same constant voltage provides them with uninterrupted electricity.

In existing methods of battery control, its voltage is controlled by $U_{\text{char}(\text{dischar})}$ and $I_{\text{char}(\text{dischar})}$ (electrical parameters char-Charge, charge-discharge), and also by temperature t^0 , which is not an electrical paramtri. In all existing electrochemical systems from a practical Jack, the voltage will be nonlinearly connected to the capacitance. We can see this in Figure 1 below.

In the process of this assembled simulation, the following results were obtained. The charging process of a type of accumulator of different capacities according to the charging voltage, charge current, charge level and ambient current consumption is shown in Figure 2.

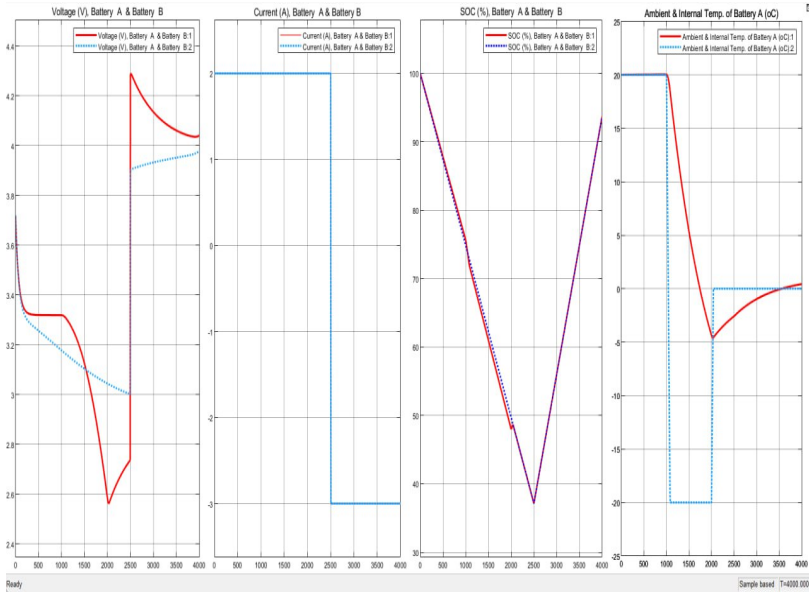

Fig. 2. Graphs of the dependence of voltage, current charge level and external temperature on the control of technical parameters of high-capacity lead-acid storage batteries.

Based on these results, the scheme of the basic control of the charging transformer part of devices providing continuous electricity was built using the Proteuz program (Figure 3).

The electrical scheme of the battery management and control system is presented in Figure 3.

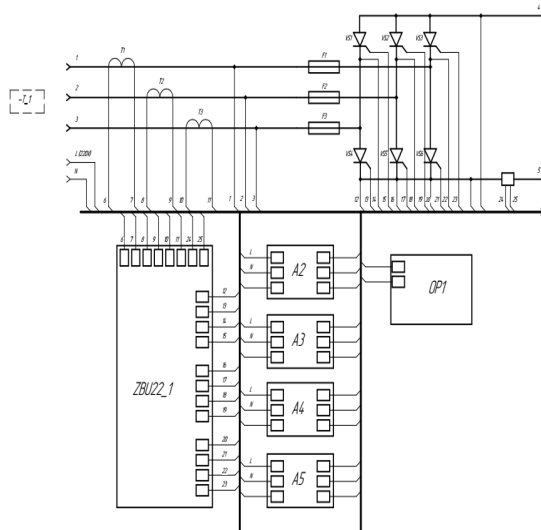

Fig. 3. Electrical circuit of battery management and control structure.

The main elements of the structure:

- T1-T3 – current transformers;
- F1-F3 – soluble preservatives;
- VS1-VS6- rectifier thyristors;
- ZBU22_1 – control board;
- A2-A5 - thyristor control devices;
- OP1 is a monitor

4 Conclusion

It is possible to determine the charge capacity of the current working system in general through its voltage and current, but it is not possible to determine the condition of each of its batteries. There are currently 110 accumulator batteries of which 54 batteries are connected in series in 2 parallel networks, each accumulator battery has an energy capacity of 2000 Ampere hours. In this case, if one of the 54 consecutive batteries fails, only one network remains in the parallel network, and the remaining batteries are 2 times more loaded and the discharge time is 2 times shorter.

In addition, it takes a lot of time to determine which battery has the problem. To prevent this, the following recommendations have been developed

- Each battery is equipped with sensors that monitor the state of the battery and display the data.
- Control and control panel improvements and software updates
- Provide a separate control panel for charge-discharge rectifier devices and separate control panel for inverter and converter
- Making it possible to monitor battery status through Wi-Fi devices, taking into account the development of modern devices.

Modern uninterruptible power supplies have been shown to work for more than 100,000 hours without failure, but it is important to monitor its condition before bringing it to this point.

Taking into account the technical condition of the uninterruptible power supply devices of Navoiy BGQ-1 IES, the most optimal of the mentioned and made recommendations is to monitor the voltage, current, amount of charge in the battery and calculate how long it will take depending on how much charge is used. It is necessary to make a program that displays this information on the screen.

References

1. Decision of the President of the Republic of Uzbekistan on the strategy of further development and reform of the electric power industry in the Republic of Uzbekistan 4249 (2019)
2. Republic of Uzbekistan Podgotovitelnyy obzor Project modernization of Navoiyskoy teploelektrostantsii: Agency for international cooperation (JICA) (2013)
3. A.A. Korshikova, *Prime nitelno k PGU-450T dissertation* (Moscow, 2015)
4. V.N. Loginova, Development of automated system control of parameters and diagnostics of battery batteries explanatory note to final qualification work (2016)
5. N. Ataulayev, A. Ataulayev, S.M. Karimtoшовich, IOP Conference Series: Materials Science and Engineering (2021)

6. Fam Kong Tao: dissertation and application of the candidate of technical sciences in Novocherkassk (2019)
7. K.V. Dobrego, Y.V. Bladyko, *Energetika. Proc. CIS Higher Educ. Inst. and Power Eng. Assoc.* **64(1)**, 27-39 (2021)