

Automated rectification of pulse response characteristics in radio engineering two-stage amplifiers

Azizjon O. Ataulaev^{1*}, *Odil X. Ataulaev*², and *Farkhod A. Ergashev*³

¹Department of Mechanical Engineering, Navoi State Mining and Technological University, Navoi, 210100, Uzbekistan

²Department of Technological Education, Navoi State Pedagogical Institute, Navoiy, 210100, Uzbekistan

³Department of Metrology, Technical Regulation, Standardization and Certification, Tashkent State Technical University named after I.A. Karimov, Tashkent, 100001, Uzbekistan

Abstract. The paper considers the practical application of the theory of optimal design of circuit devices with feedback and desired characteristics on the example of two-line amplifiers of radio under the scheme with the common amplifier. Since the order of the differential equations describing the dynamics of the test device depends on the number of amplification stages it is shown that the problem is solved in the same way and for amplifiers with a large number of stages. It is proven that the technical realization of the synthesized control law is quite simple.

1 Introduction

The sharp leap that has taken place in recent years in the field of the use of radio-electronic systems in many fields of science and technology, with a simultaneous increase in the requirements for the dynamic and accuracy characteristics of such systems, has led to the widespread use of control theory methods in them. The increased requirements for radio-electronic control systems make it necessary to use an adequate mathematical apparatus in their design. In this case, such an apparatus is the theory of dynamic optimization, which is widely used in the theory of optimal control.

At the same time, the efficiency of designing such systems is greatly increased, since the design procedure is almost completely amenable to automation [1, 2]. Currently, intensive research is underway on the problems of automating the technical implementation of the synthesized control algorithms using a digital computer and microcomputer [3, 4]. The application of the methods of the theory of optimal design in the problems of radio electronics makes it possible to increase the efficiency of designing these systems with a simultaneous improvement in their characteristics.

* Corresponding author: aziz-217@mail.ru

2 Materials and methods

The problem of designing an optimal system can be formulated as follows: a control object or process is given; it is required to find a control law or a control sequence of actions that deliver the maximum or minimum of a given set of system quality criteria.

In some cases, all system state coordinates are directly measurable and observable. For linear systems with this property, the formation of the optimal control law as a function of state coordinates can be performed even in the presence of measurement noise. In engineering practice, very often not all coordinates of the system state allow direct observation and measurement. In these cases, the optimal control law is determined as a function of the best estimates of the state coordinates determined from measurements of the system output signals. Therefore, the optimal control problem in a more general setting includes both the optimal estimate problem and the optimal control problem [5].

The value of optimization theory in the synthesis of feedback control systems lies mainly in its flexibility as a direct method for the synthesis of high-quality systems in the time domain.

The following methods are most often used in the design of control systems: calculus of variations, Pontryagin's maximum principle, and Bellman's dynamic programming. In all cases, the ultimate goal is to determine the optimal control law or control sequence of actions that lead to the maximum or minimum of a given functional that characterizes the quality of the system.

Modern tracking complexes and installations are systems that must meet the current maximum achievable requirements for the accuracy and dynamics of controlling the coordinates of the nodes and blocks that form their structure.

From the point of view of the analysis and synthesis of radio-electronic systems, it seems appropriate to divide all the variables that characterize the system or have a certain relation to it into three groups: input variables or influences u_i , representing signals generated by systems that are external to the system under study and do not affect its behavior; output variables (measured), characterizing the response of the system y_i and allowing to describe some aspects of the system behavior that are of interest to the researcher; state variables (coordinates) or intermediate variables x_i characterizing the dynamic behavior of an electronic system.

3 Results and discussion

At any given time t , the state of the process is a function of the initial state $t(x_0)$ and the input vector $u(t, t_0)$, i.e.

$$\dot{x}(t) = f[x(t), u(t)] \quad (1)$$

or in scalar form

$$\dot{x}_i(t) = f_i[x(t), u(t), t], i = 1, 2, \dots, n. \quad (2)$$

The output vector - the measured output signal - is determined by the relation

$$y(t) = g[x(t), u(t), t], \quad (3)$$

which is applicable in most tasks of control of radio-electronic objects.

The dynamic process can also include the saturation equations

$$u(t) \in U, x(t) \in X. \quad (4)$$

The notation $u(t) \in U$ indicates that the vector $u(t)$ lies inside or on the boundary of a closed region $U(t)$ of the vector space. An example of a saturation equation is the relation

$$-U_i \leq u_i(t) \leq U_i \quad (5)$$

for $i = 1, 2, \dots, n$.

The equations of linear radio electronic systems are written in the form

$$x(t) = Ax(t) + Bu(t) + v(t). \tag{6}$$

Where $x(t)$ is the n -dimensional state vector, u is the m -dimensional control vector, and v is the n -dimensional perturbation vector. The equation for the measured output signal can be represented as

$$y(t) = Cx(t). \tag{7}$$

If the dynamic process is linear and saturation does not take place, then the saturation equations are simply omitted. In equations (6) and (7), the matrices A , B and C have the form

$$A = \begin{bmatrix} a_{11}(t) & a_{12}(t) & \dots & a_{1n}(t) \\ a_{21}(t) & a_{22}(t) & \dots & a_{2n}(t) \\ \dots & \dots & \dots & \dots \\ a_{n1}(t) & a_{n2}(t) & \dots & a_{nn}(t) \end{bmatrix},$$

$$B = \begin{bmatrix} b_{11}(t) & b_{12}(t) & \dots & b_{1m}(t) \\ b_{21}(t) & b_{22}(t) & \dots & b_{2m}(t) \\ \dots & \dots & \dots & \dots \\ b_{n1}(t) & b_{n2}(t) & \dots & b_{nm}(t) \end{bmatrix},$$

$$C = \begin{bmatrix} c_{11}(t) & c_{12}(t) & \dots & c_{1n}(t) \\ c_{21}(t) & c_{22}(t) & \dots & c_{2n}(t) \\ \dots & \dots & \dots & \dots \\ c_{n1}(t) & c_{n2}(t) & \dots & c_{nn}(t) \end{bmatrix}. \tag{8}$$

The problem of optimizing the impulse response under consideration is solved for a two-stage linear amplifier using a common-emitter circuit. This problem is similarly solved for an amplifier with a large number of stages. It is assumed that each cascade can be represented by a simple transfer function

$$Wp = \frac{K_i}{p + \omega_{ic}} = \frac{K'_i}{1 + pT'_i} \tag{9}$$

Where $K_i = \frac{K'_i}{\omega_{ic}}$, ω_{ic} is the conjugate frequency of the i -th stage.

The output voltage of each stage can be used as a state variable. The block diagram of the amplifier is shown in Figure 1. The equations corresponding to this scheme have the form

$$\dot{X}_1 = -\omega_{1c}X_1 + K_1X_2, \tag{10}$$

$$\dot{X}_2 = -\omega_{2c}X_2 + K_2U. \tag{11}$$

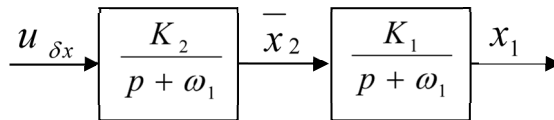

Fig. 1. Block diagram of the amplifier.

If the duration of the pulse shape input signal is greater than the time constant of the i -th stage $T_i = 1/\omega_k$, the output signal of the amplifier will consist of transition sections between steady states. Since the output signal has the same shape, it is sufficient to consider only one transition section. In this case, equations (10), (11) can be rewritten in variations from their steady-state values

$$x_1(t) = X_1(t) - X_1(\infty), \tag{12}$$

$$x_2(t) = X_2(t) - X_2(\infty), \tag{13}$$

hence

$$\dot{x}_1 = -\omega_{1c}x_1 + K_1x_2, \tag{14}$$

$$\dot{x}_2 = -\omega_{2c}x_2 + K_2u, \tag{15}$$

where u is the variation of the input signal amplitude.

The task of synthesizing an auto corrector is to determine the increment of the input signal u^* , minimizing the quality functional during the transition time of states from $t = 0$ to $t = \infty$.

For an n -stage amplifier, the equations of state (14), (15) can be written in vector form

$$\dot{x}(t) = Ax(t) + Bu(t), \tag{16}$$

where x is an n -dimensional state vector, A is an $n \times n$ -matrix, B is a column matrix of dimension n .

The next step in solving the problem of the dynamic properties of the amplifier is to form a quality criterion that reflects the requirements for performance:

$$J = \int_0^\infty (x^T Q x + u^T L u) dt. \tag{17}$$

The measure of error used in this functional "requires" the transfer of the system to a steady state with limited energy going to the control. Linear equations and a quadratic measure of error make it possible to find the auto corrector equation minimizing functional (17) using the matrix Riccati equation

$$\dot{P} = -PA - A^T P - Q + PBL^{-1}BP. \tag{18}$$

Then the control equation

$$u = -L^{-1}B^T P x, \tag{19}$$

is found from

$$u^* = -L^{-1}B^T P x(t). \tag{20}$$

In this case

$$P(t) = P(\infty), \tag{21}$$

and can be found from the equation

$$Q - PBL^{-1}B^T P + PA^T + PA = 0, \tag{22}$$

which is the right side of the matrix Riccati equation. Once P has been calculated, the correction equation can be rewritten as

$$u^*(t) = Gx(t), \tag{23}$$

where G – $n \times m$ -matrix-constant of linear optimal auto-correction, m – dimension of the auto-correction vector $u(t)$.

For a two-stage amplifier

$$u^*(t) = \begin{vmatrix} g_1 & 0 \\ 0 & g_2 \end{vmatrix} \begin{vmatrix} x_1 \\ x_2 \end{vmatrix} = g_1 x_1 + g_2 x_2. \tag{24}$$

The block diagram of the implementation of equation (23) for a two-stage amplifier is shown in Figure 2. The feedback coefficients g_1 and g_2 are found as a result of solution (22) written for $n = 2, m = 1$. The feedback calculated for the variation of states x is also optimal for the absolute values of X , since the amplifier is linear.

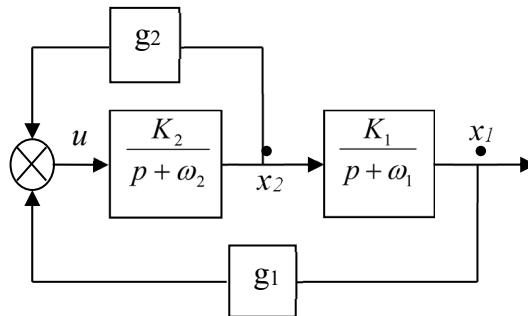

Fig. 2. Structural diagram of a two-stage amplifier.

For the case when $m = 1$ (i.e., u is a scalar), expressions (16), (22), (23) can be arranged as follows: from (16) and (23) it follows that

$$G = -L^{-1}B^T P, \tag{25}$$

hence

$$P = \frac{G}{-L^{-1}B^T}. \tag{26}$$

Taking into account (25), (26), equation (22) is transformed to the form

$$Q + \frac{G}{-L^{-1}B^T}G + \frac{G}{-L^{-1}B^T}A^T + \frac{G}{-L^{-1}B^T}A = G^2 + GA^T + GA + QL^{-1}B^T = 0. \tag{27}$$

For a two-stage amplifier, the equations of state and the quality criterion in the case under consideration can be represented as

$$\begin{bmatrix} \dot{x}_1 \\ \dot{x}_2 \end{bmatrix} = \begin{bmatrix} a_{11} & a_{12} \\ a_{21} & a_{22} \end{bmatrix} \begin{bmatrix} x_1 \\ x_2 \end{bmatrix} + \begin{bmatrix} b_{11} \\ b_{21} \end{bmatrix} |u|, \tag{28}$$

$$J = \int_0^\infty \left\{ \begin{bmatrix} x_1 \\ x_2 \end{bmatrix}^T \begin{bmatrix} q_{11} & 0 \\ 0 & q_{22} \end{bmatrix} \begin{bmatrix} x_1 \\ x_2 \end{bmatrix} + l_{11}u \right\} dt, \tag{29}$$

Where $a_{11} = -\omega_{1c}$; $a_{12} = K_1$; $a_{21} = 0$; $a_{22} = -\omega_{2c}$; $b_{11} = 0$; $b_{21} = K_2$; $q_{11} = 1$; $q_{22} = d$; $L = l_{11}$ – scalar

Substituting (28) and (29) into (25) allows one to obtain analytical expressions for determining the feedback coefficients

$$\begin{aligned} G &= \begin{bmatrix} g_1 \\ g_2 \end{bmatrix}, \\ g_1^2 + 2a_{12}g_1 + 2a_{11}g_1g_2 - \frac{1}{l_{11}} &= 0, \\ g_2^2 - 2a_{22}g_2 + 2b_{12}g_1 - \frac{\alpha}{l_{11}} &= 0. \end{aligned} \tag{30}$$

A schematic diagram of an amplifier with an auto-corrector is shown in Figure 3.

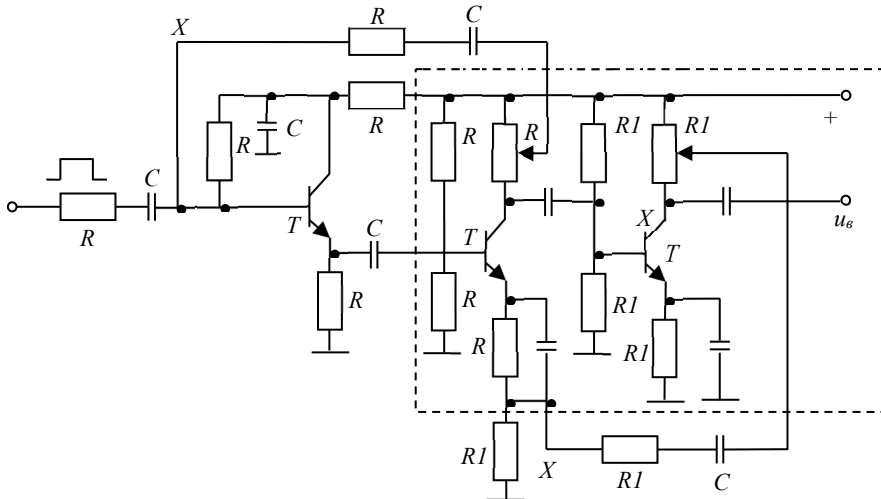

Fig. 3. Schematic diagram of an amplifier with an auto-corrector.

The original part of the circuit, made on transistors $T2$ and $T3$, is circled with a dotted line. The loads of the cascades are resistors $R8$, $R13$, from which the signals of state variables $x1$, $x2$ are taken. The feedback circuits consist of resistors $R5$, $R15$, as well as separating

capacitances $C8$, $C13$, which prevent the passage of constant voltage components to the input of the amplifier. The feedback depth is adjusted using potentiometers $R8$, $R13$.

4 Conclusion

The considered problem illustrates the effectiveness of designing "simple" circuit devices with given characteristics and the technical implementation of the synthesized control law is quite simple.

References

1. O.Kh. Ataulaev, A.O. Ataulaev, B.T. Bisenova, Seybold Report Journal (TSRJ) **17(12)**, 451-461 (2022)
2. R.O. Muminov, G.E. Rayhanova, D.A. Kuziev, Experimental research and analysis of a quarry drilling rig/ Ugol' **5**, 32-36 (2021). <https://www.doi.org/10.18796/0041-5790-2021-5-32-36>
3. D.A. Kuziev, V.V. Zotov, E.S. Sazankovaa, R.O. Muminov, Eurasian Mining **37(1)**, 76-80 (2022). <https://www.doi.org/10.17580/em.2022.01.16>
4. A.A. Irgashev, F.A. Ergashev, *Screw conveyor with anti-friction polymer coating for cotton transportation*, Annual International Scientific Conference on Agricultural Engineering and Green Infrastructure Solutions (AEGIS-2021) 20-21 May, Tashkent, Uzbekistan (2021)
5. U. Attokurov, S. Omorova, D. Eshmuradov, Science and Innovation **1(6)**, 484-488 (2022)