

A Comparison of Fiber Types in Community for Mist Collection

Thana Ananacha ¹, and Onvalee Amornleetrakul ^{1,*}

¹Faculty of Architecture and Design, King Monkut's University of Technology, Bangkok, Thailand

Abstract. The production of clean water from evaporated water in fog has been very attractive in recent decades. Massive fog accumulation combined with simple concepts and technologies with respect to water production has resulted in sustainable environmental impact in producing clean, low-cost water for arid areas around the world. Mist collection systems work best in locations with repetitive fog conditions where fog is driven by wind especially coastal areas. However, the technology can also be used in mountainous areas where there is water in the Stratocumulus clouds at elevations of about 2,000-6,500 feet. The purpose of this research was to compare the fiber types that collect mist water by testing with atmospheric conditions in Khao Yai Thiang, Nakhon Ratchasima Province, which is 800 meters above sea level to produce water for the community and suitable for Thailand. The test was carried out by stretching 12 different fibers to a wooden frame measuring 0.50 x 0.50 m² and installing it horizontally. Field tests found that three types of horizontal water droplet materials, which were the best mist water collector, are synthetic fibers: nylon net, plastic net, and polyethylene net. All three materials behave very differently. Especially, the temperature profile of the plastic net has the highest temperature in the afternoon and the lowest temperature in the night. Nylon net has a temperature close to the air temperature throughout the day but slightly lower. These materials will be used in the design of the moisture trap tower in the next experiment. In the first experiment, there was not much water and water droplets clinging to the fibers as blotted dots with tissue paper because the fog period is not long enough.

Keyword. Fiber, Fog, Mist water, Water tower, Water trap

1 Introduction

Nowadays, there are many building designs that take advantage of the natural environment and improve the quality of life for people to live more comfortably, such as concrete block wall (CBW) blocks that reduced the internal temperature to 1.9 - 2.9 °C lower than ordinary glass [1], Thai Modern Façade (TMF) and Thai Modern Façade Wall with Fin (TMF-WF) wall that reduced heat flux flowing into room [2], vapor recovery tower (VRT) roof that include flow rate and reduce average room temperature about 1.41 °C compared with ordinary concrete tiles [3] or even the technology of big tree stilts that make the environment better [4].

Misty water is a freshwater source that is available at low cost. It can be a source of drinking water for communities in foggy conditions. There are studies on the accumulation of mist water in more than 20 countries around the world on all continents, especially, in areas where the phenomenon of high fog occurred. Additionally, collecting mist water is beneficial when rivers or lakes are far away or dehydrated and suitable for countries with a semi-arid climate in the tropics or subtropics [5].

Mist is the presence of water droplets that fall on the ground level as part of the water cycle. Mist form overnight, with diameter range of 1 - 50 µm [6]. This is because the cold ground causes water vapor to condense

in the air above [7]. Many studies found that a steady decrease in fog was observed in many areas with dense fog, including large coastal cities like California in the United States and many areas of Europe [8-10]. However, China and India were found to have increased fog [11,12]. Global warming is a theory that reduces the phenomenon of fog in some areas. It affects local atmospheric and wind circulation patterns, as well as inversion patterns [10]. The method of harvesting fog water is quite simple, using a net stretched to the frame. When the mist hits the net, it condenses into water droplets and flows to gather in the prepared water reserve container. However, the difficulty is prediction of the amount of fog.

Due to the lack of standards for measurement and reporting of data [13], only the mean or maximum value was considered in many studies. In 1994, Schemenauer and Cereceda designed a Standard Fog Collector (SFC) [14], which consisted of a 1.00 x 1.00 m² frame stretched by a net, attached to the 2 side posts with a height of 2.00 meters, with a distance of 0.10 meters from the posts. Under the net frame, the water chute dimension L x W x D is 1.04 x 0.15 x 0.10 m³, whose details are shown in Figure 1. Mist collection rates range from 1 - 10 l/m².day, but can reach 40 l/m².day in some regions [14].

* Corresponding author: onvalee.a@archd.kmutnb.ac.th

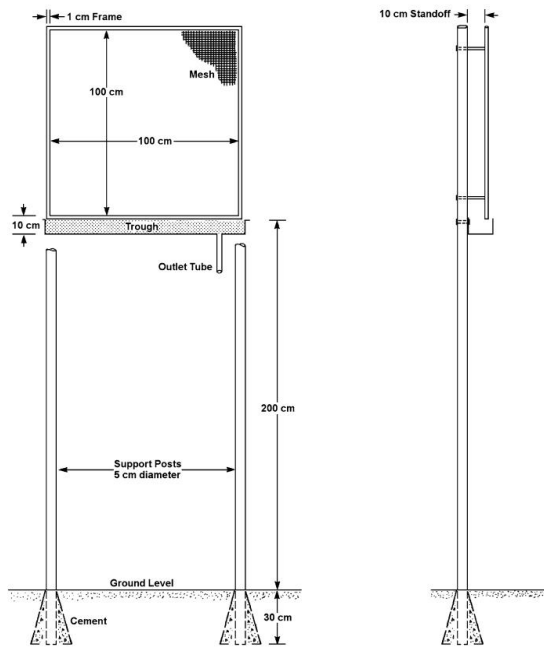

Fig. 1. Standard Fog Collector: SFC [14]

2 Materials and methods

The main objective of this research is to provide an alternative water resource from fog water for people in areas with difficult access to water such as mountainous areas by choosing technology that is easy for the community. In this experiment, it is a preliminary experiment to test the quality of fibers available in the market to collect mist water and to extend the design of the fog trap tower in the next experiment. To achieve these objectives, we, therefore, selected the investigated area based on the published research data.

From the study of air humidification towers in many countries around the world, such as Chile, Namibia, Spain, Greece and others. The optimum climate is on mountainous terrain 400 - 1,200 meters above sea level. Most of them are near water sources because the terrain is hot during the day and cool at night. In case of high humidity from being near a water source, it can create a mist texture easily. Nakhon Ratchasima Province is a province in the northeastern region and has a plateau and mountains. Therefore, it is suitable in many areas around the world. Khao Yai Thiang has a height of 650 meters above sea level witch close to Lam Ta Khong Dam making the environment suitable complete the components of the fog. Field test location has taken into account various factors, the location that is expected to cause a lot of humidity power supply and the safety of experimental equipment. The inner cliff area was the good choice, which is next to the viewpoint, safe for experimental equipment and near the waterway that drains from the reservoir above. With these reasons, it is expected to help generate a lot of humidity. The location of the field test is at approximate coordinates 14°48'11.21"North and 101°33'11.13"East as seen in Figure 2.



Fig. 2. Field test area at Lam Ta Khong Dam, Nakhon Ratchasima

Field testing is a test of the properties of commercially available fibers, both natural and synthetic fibers to find the best fiber for water retention. In this experiment, a small frame was made, consisting of two main parts: the frame for holding the fibers and the stand structure. The fiber was tested horizontally because of the small-sized fibers and in a location covered by trees, which the vertical panel cannot be set to a high height and there is no misty wind in this area.

The frame for fixing fibers is made from structural timber, size 1x 1.5 inches, with a total size of 0.50 x 0.50 m², 12 pieces, used for fixing fibers in the test as shown in Figure 3. The stand structure is made up of structural timber measuring 1.5 x 1.5 inches in total size of 2.00 x 0.50 x 0.50 m³, 3 sets. The frame used to hold the fibers can be removed and placed on the stand structure as shown in Figure 4.

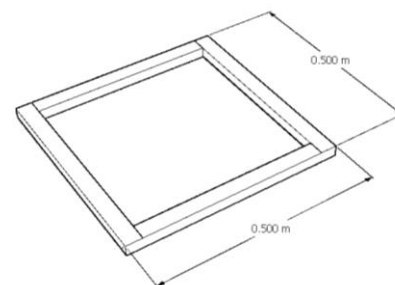

Fig. 3. Frame for fixing fibers

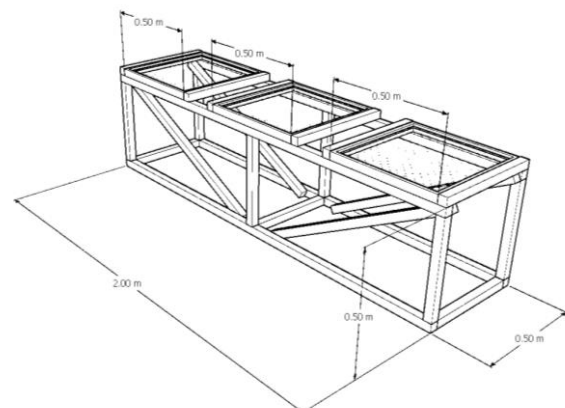

Fig. 4. Stand structure and frame placed on stand structure (1 stand set)

Twelve different fibers were stretched to a wooden frame measuring 0.50 x 0.50 m² and mounted

horizontally. There are two types of fiber types: natural fibers and synthetic fibers. Natural fibers are hemp fiber, pineapple fiber, woven bamboo and cotton yarn (holy thread). Synthetic fibers are nylon mosquito net, plastic netting, small nylon net, plastic netting (onion bag), hexagonal eye PVC grille, nylon rope, big nylon net and polyethylene mesh (Figure 5). The temperature sensors were attached to the skin in the middle of the fiber sheets to investigate the thermal behavior as arranged in Figure 5. The field test was conducted during April 10-17, 2020, and the following weather data was collected.

- Dry Bulb Temperature: (T, °C)
- Dew Point Temperature: (Td, °C)
- Relative humidity (Relative Humidity: RH, %)
- Wind speed (Wind Velocity: V, m/s)

3 Results and Discussion

The overall climate is shown in a continuous graph in

Figure 6. The graph shows results between 0.00 a.m. on April 11, 2020 to 7.00 a.m. on April 17, 2020. It can be observed that in different positions circled as follows:

- 1 - On April 12th, rain occurred between 2.10 - 3.50 p.m., causing the temperature to drop sharply from 31.8°C to 22.7°C or a decrease of 9.1°C.
- 2 - And thus the relative humidity increased from 52.1% to 84.4% during the period.
- 3 - When combined with the decrease in temperature in the evening and moisture accumulation, the humidity increased to reach 100% between 1.35 a.m. and 2.05 a.m. and the humidity exceeds 100% (more than the devices can collect data) between 6.20 a.m. to 8.00 a.m. on April 13, 2020.
- 4 - The same temperature between T and Td between 6:20 a.m. and 8:00 a.m. was observed on April 13, 2020, which was the timing for fog to form and fall on the fibers as water droplets and can absorb moisture.



Fig. 5. Fiber installation in the test area

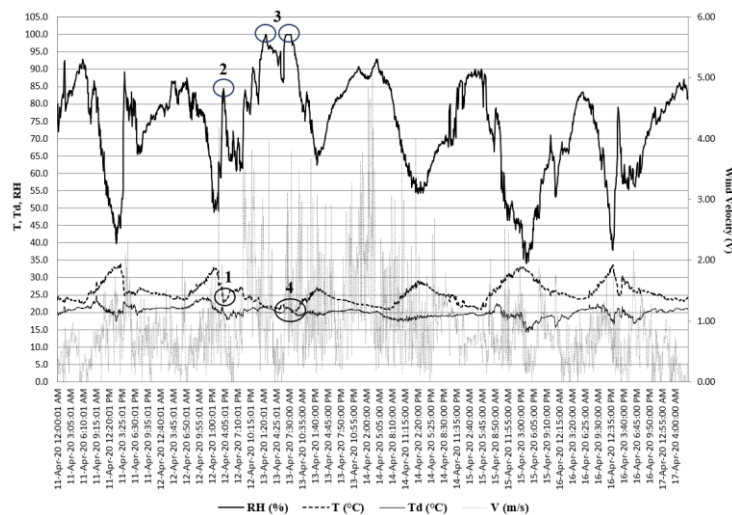

Fig. 6. Climate conditions in the experimental area during 11 - 17 April 2020

Figure 7 shows a graph of climate phenomena on April 12 - 13, 2020 (fog day), which is clearly visible to overlapping curves of apparent dry bulb temperature: T, dew point temperature: Td and relative humidity: RH reaching 100% as far as the instrument can be measured. During 1.35 a.m. - 2.05 a.m., the average wind speed was 0.85 m/s, the maximum wind speed was 1.38 m/s, and during 6.20 - 8.00 a.m., the average wind speed was 1.61 m/s and maximum measurement up to 3.80 m/s.

Temperature results of various materials can be seen in Figures 8 and 9. Figure 8 shows the continuous temperatures of 12 materials for 6 days from 11 April 2020 at 0:00 a.m. to date April 17, 2020 at 7:00 a.m. can be seen that, during the night until early morning, all materials have a temperature drop below the dry bulb temperature. If the temperature profile is divided into 2

- Low temperature period, 4:00 p.m. - 9:00 a.m.
- High temperature period, 9.00 a.m. - 4.00 p.m.

The results show that at the low temperature range, the materials with the lowest temperature are nylon mosquito nets. At the high temperature range, the highest temperature material is plastic net.

Figure 9 shows a graph comparing the temperature of various materials and the dry bulb temperature on April 13, 2020 (fog day) from 0.00 a.m. - 23.55 p.m. to see more clearly the temperature of each material. In order to see more clearly the temperature of each material, a comparison chart of skin temperature separation between natural fibers and synthetic fibers are shown in Figures 10 and 11, respectively.

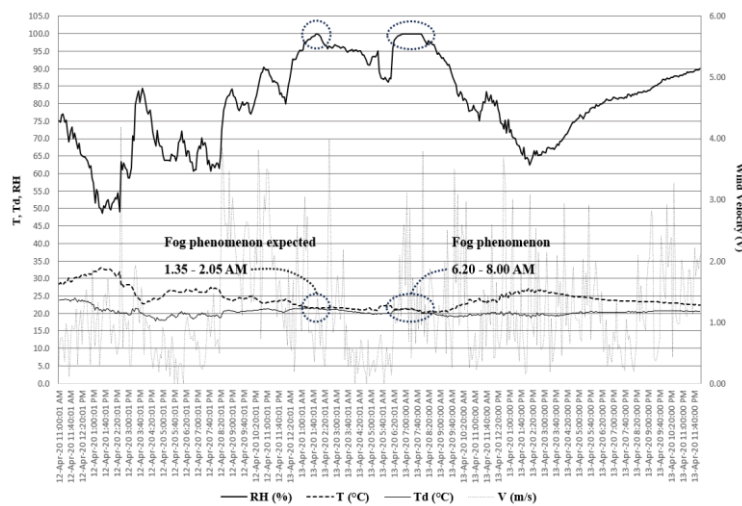

Fig. 7. Climate conditions in the test area during 12 - 13 April 2020.

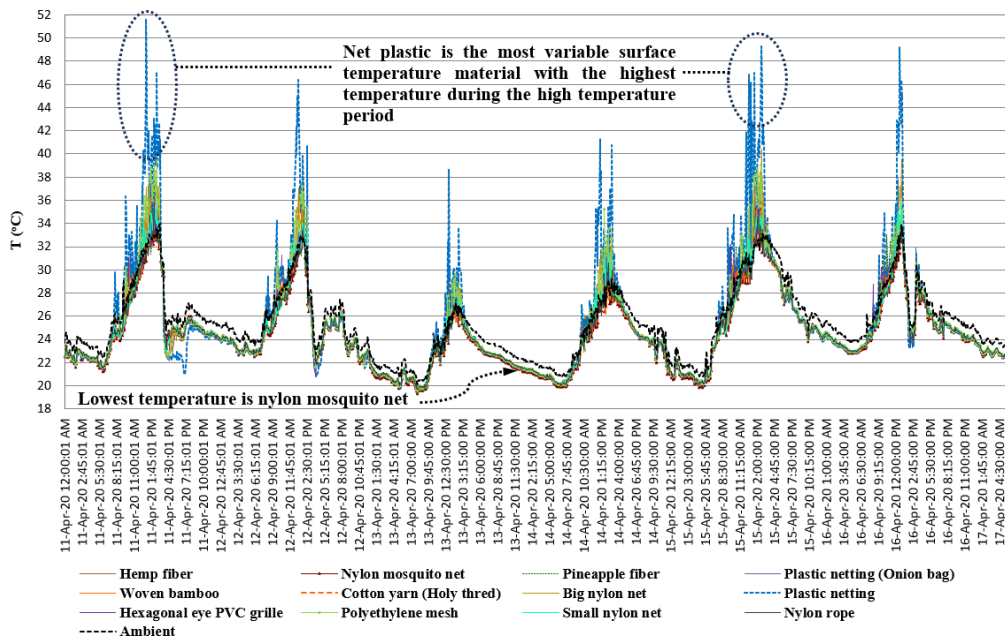

Fig. 8. Comparison graph of the surface temperature of 12 material fibers for 6 days during 11 - 17 April 2020 time periods, which are:

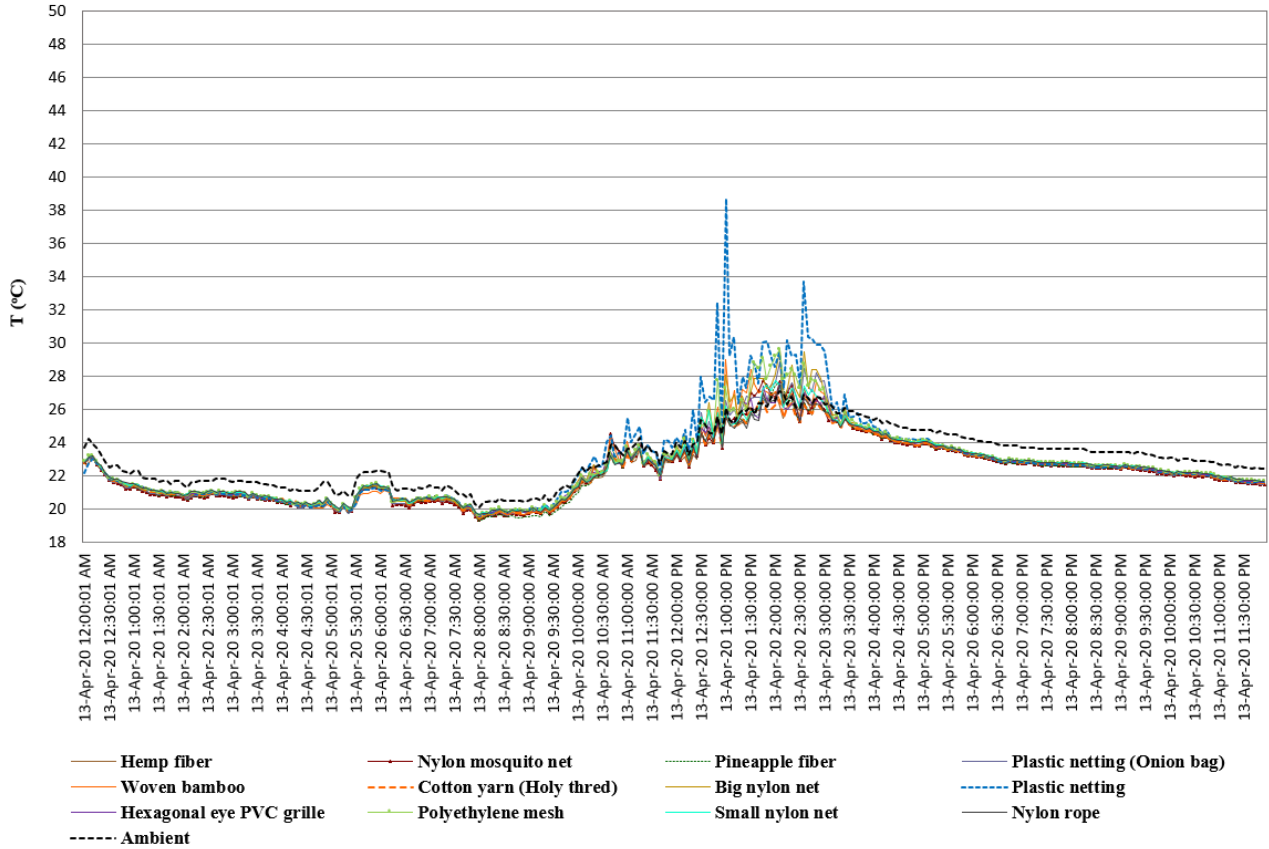

Fig. 9. Comparison graph of the surface temperature of material fibers on April 13, 2020

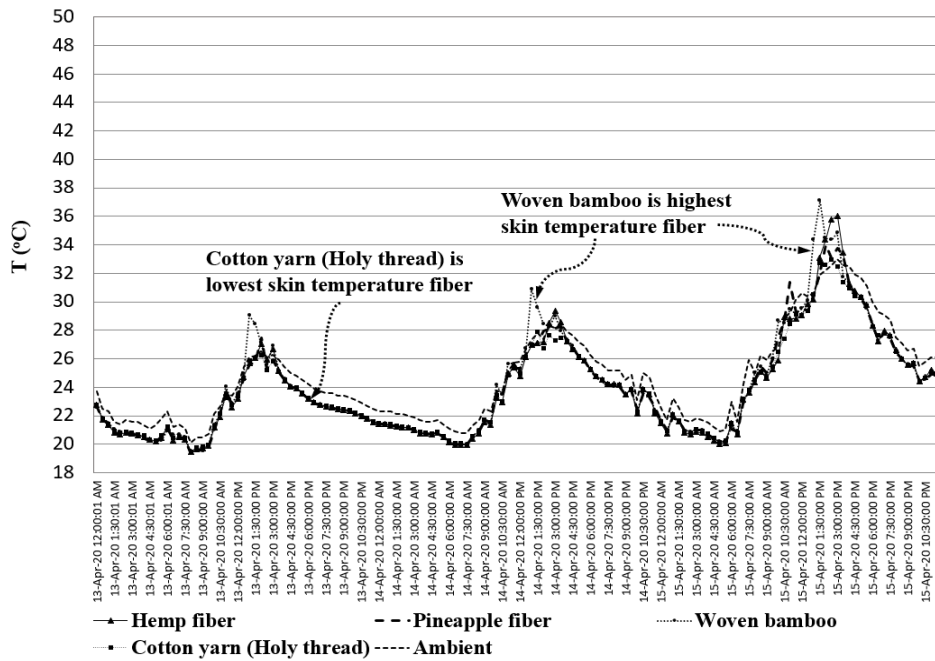

Fig. 10. Natural fiber surface temperature comparison during 13 - 15 April 2020

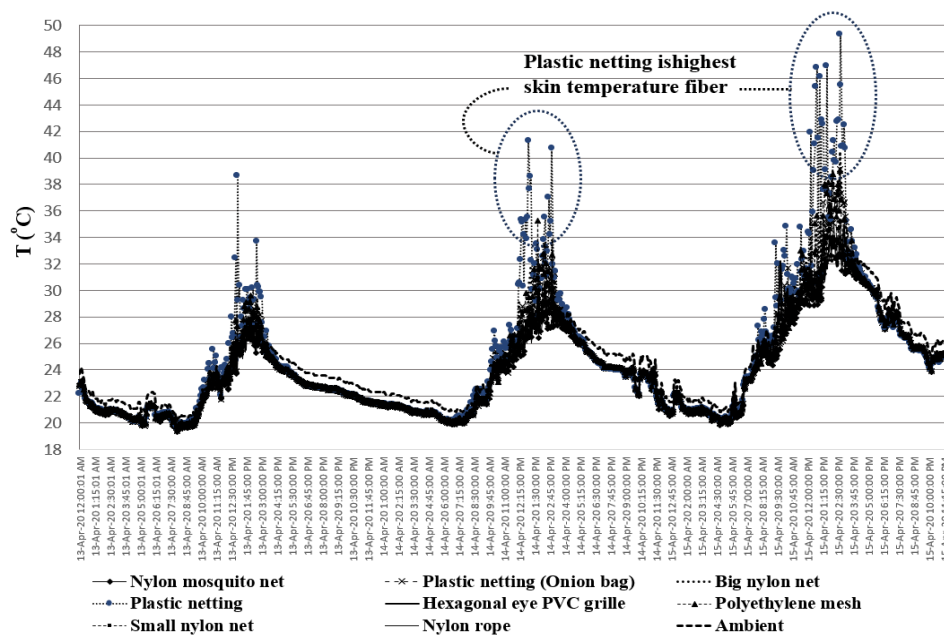

Fig. 11. Synthetic fiber surface temperature comparison during 13 - 15 April 2020

In Figures 10 and 11, fibers can be divided into 2 groups:

- High-temperature fibers sorted in order: woven bamboo, pineapple fiber, plastic net, small nylon net, plastic net (onion bag), big nylon net and polyethylene mesh.
- Low-temperature fibers sorted in order: hemp fiber, cotton yarn (holy thread), nylon net (blue), hexagonal eye PVC grille and nylon rope.

From the 6-day observation, it was found that the material with the highest temperature during 12.00 p.m. - 3.00 p.m. was plastic net and the lowest temperature material in the low temperature range (4.00 p.m. - 9.00 p.m.), they include nylon net, plastic net and pineapple fiber with maximum, minimum and average temperatures as shown in Table 1.

For fiber mist water collection effect in this experiment, we tested the water that was absorbed with toilet paper on the fiber sheet on April 13, 2020, which has a fog period of approximately 1 h and 40 min (6.20 a.m. - 8.00 a.m.). During approximately 7.00 a.m.- 7.30 a.m. and found that among three types of fibers that had the most water droplet adhesion were nylon net, plastic net and polyethylene mesh. Other materials absorbed very little or no water at all, therefore showing only three types that could absorb water as in Figure 12.

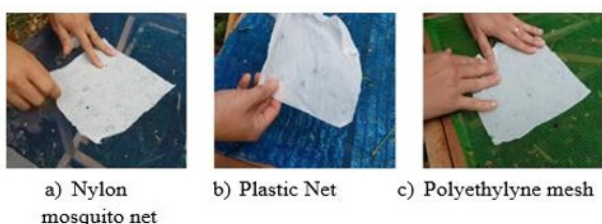

Fig. 12. Three materials with the best retained water from mist.

Figure 13 showed a comparison graph of three materials that absorbed water the best, namely nylon mosquito net, plastic net and polyethylene mesh, respectively. Environmental condition data of 6 consecutive days, during 11 - 17 April 2020, showed the behavior of different materials. Nylon mosquito net had a surface temperature value similar to air temperature. It was slightly lower in both high and low temperature ranges and had the lowest average surface temperature on foggy days, 21.67°C and the lowest average temperature for several days.

The plastic net had the greatest fluctuations in surface temperature. When the air temperature was higher, the surface temperature was significantly higher than that of other materials. Especially, on a hot day in April 11, 2020, the maximum surface temperature had increased to 51.64°C, while the low temperature range value of the plastic net was relatively low. It also had a minimum temperature of 22.05°C, which was lower than the nylon net. Therefore, plastic net is the material with the widest temperature range.

Polyethylene mesh was the most woven fiber that had the highest surface temperature after the plastic net, with the highest surface temperature reaching 39.42°C and the lowest temperature was even higher than that of nylon net and plastic net.

Fog water collection in the first experiment was quite difficult to explain which of these 3 fibers collected the most fog. Due to the difference in water droplets characteristics, nylon mosquito net water droplets are distributed in small pellets. Plastic net produced large droplets, but are far apart and polyethylene mesh produced droplets of both small and large water droplets. However, the problem with polyethylene mesh is the complexity of the fibers. This makes water droplets trap inside and harder to extract water out.

Table 1. The max., min., and avg. temperatures of 12 material fibers and dry bulb temperatures.

List	Values	11 Apr.	12 Apr.	13 Apr.	14 Apr.	15 Apr.	16 Apr.
1. Hemp fiber	Max.	36.34	35.98	27.27	30.59	36.01	34.39
	Min.	21.32	22.54	19.45	19.95	19.92	22.85
	Avg. (12.00-15.00)	33.30	31.11	25.34	27.25	32.48	28.77
	Avg. (16.00-9.00)	24.17	22.10	21.69	22.92	25.29	24.23
2. Nylon mosquito net	Max.	34.59	34.82	26.98	30.16	34.08	33.47
	Min.	21.33	22.51	19.33	19.89	19.83	22.82
	Avg. (12.00-15.00)	32.10	30.49	25.53	26.88	31.67	28.52
	Avg. (16.00-9.00)	24.20	22.10	21.67	22.94	25.30	24.24
3. Pineapple fiber	Max.	34.53	34.66	26.87	29.38	34.99	33.65
	Min.	21.38	22.57	19.27	19.95	20.09	22.79
	Avg. (12.00-15.00)	31.95	30.56	25.34	27.24	31.94	28.82
	Avg. (16.00-9.00)	24.07	22.06	21.70	22.96	25.21	24.21
4. Plastic Net (onion bag)	Max.	37.98	38.08	28.84	32.46	37.19	34.02
	Min.	21.34	22.53	19.40	19.90	19.92	22.81
	Avg. (12.00-15.00)	34.57	32.19	26.05	28.49	33.68	29.14
	Avg. (16.00-9.00)	24.01	22.09	21.71	22.96	25.29	24.22
5. Woven bamboo	Max.	37.48	36.82	28.42	31.42	37.12	37.76
	Min.	21.48	22.61	19.44	19.96	20.10	22.78
	Avg. (12.00-15.00)	33.87	31.95	25.98	28.48	33.56	29.66
	Avg. (16.00-9.00)	24.04	22.08	21.74	23.01	25.22	24.22
6. Cotton yarn (Holy thread)	Max.	33.84	33.21	26.56	29.94	34.56	33.85
	Min.	21.40	22.61	19.46	19.98	20.09	22.83
	Avg. (12.00-15.00)	32.05	30.57	25.18	27.09	31.55	28.71
	Avg. (16.00-9.00)	24.14	22.13	21.75	22.98	25.27	24.25
7. Big nylon net	Max.	38.16	37.87	29.57	33.87	40.45	39.50
	Min.	21.50	22.62	19.39	20.06	20.08	22.88
	Avg. (12.00-15.00)	35.05	32.54	26.52	29.54	34.52	29.86
	Avg. (16.00-9.00)	24.12	22.18	21.80	23.07	25.38	24.32
8. Plastic net	Max.	51.64	46.36	38.68	41.31	49.32	49.22
	Min.	21.50	22.60	19.57	20.07	20.20	22.76
	Avg. (12.00-15.00)	39.56	35.73	28.39	33.03	39.74	32.61
	Avg. (16.00-9.00)	23.77	22.05	21.84	23.20	25.35	24.47
9. Hexagonal eye PVC grille	Max.	34.47	33.29	27.41	31.52	34.18	35.60
	Min.	21.47	22.66	19.56	20.07	20.16	22.86
	Avg. (12.00-15.00)	32.56	30.89	25.54	27.85	32.19	29.08
	Avg. (16.00-9.00)	24.14	22.18	21.82	23.08	25.32	24.34
10. Polyethylene mesh	Max.	39.42	36.69	29.58	35.24	38.78	37.12
	Min.	21.54	22.66	19.63	20.06	20.14	22.90
	Avg. (12.00-15.00)	35.74	32.72	26.66	29.60	34.47	29.59
	Avg. (16.00-9.00)	24.18	22.22	21.84	23.08	25.38	24.35
11. Small nylon net	Max.	35.50	34.06	27.48	31.03	34.74	35.64
	Min.	21.51	22.69	19.68	20.10	20.16	22.91
	Avg. (12.00-15.00)	33.30	31.30	25.77	28.28	32.38	29.50
	Avg. (16.00-9.00)	24.24	22.24	21.86	23.08	25.36	24.34
12. Nylon Rope	Max.	34.71	33.41	27.44	30.62	35.23	33.05
	Min.	21.51	22.71	16.67	20.04	20.08	22.94
	Avg. (12.00-15.00)	32.11	30.53	25.32	27.43	31.51	28.75
	Avg. (16.00-9.00)	24.24	22.22	21.85	23.07	25.34	24.34
13. Ambient temperature	Max.	34.00	33.00	27.10	29.20	33.10	33.90
	Min.	22.40	23.60	20.10	20.80	20.80	23.80
	Avg. (12.00-15.00)	32.40	31.10	25.70	27.50	31.50	29.50
	Avg. (16.00-9.00)	24.85	25.25	23.13	22.61	23.93	26.37

4 Conclusions

The field test found three types of materials that collected water droplets horizontally, all of which are synthetic fibers: nylon mosquito net, plastic net and polyethylene mesh. They had very different behavior, especially, the plastic net with both the highest and lowest temperatures. Nylon nets had a temperature close to the air temperature throughout the day but slightly lower.

We have noticed that on foggy days, there was often strong wind. This may be caused by high temperatures

during the day that caused a temperature difference within the mountain, resulting in strong winds, and strong winds caused a sharp drop in temperature at night, condensation and drop of water. It is also possible that the wind carries fog or steam from elsewhere.

For fibers, we found that materials with low surface temperatures during the night is synthetic materials and they could collect mist water better than natural fibers. The texture of the material and the grid spacing of the fibers have a great effect. Natural materials absorb too much water, causing no water droplets to form on the surface.

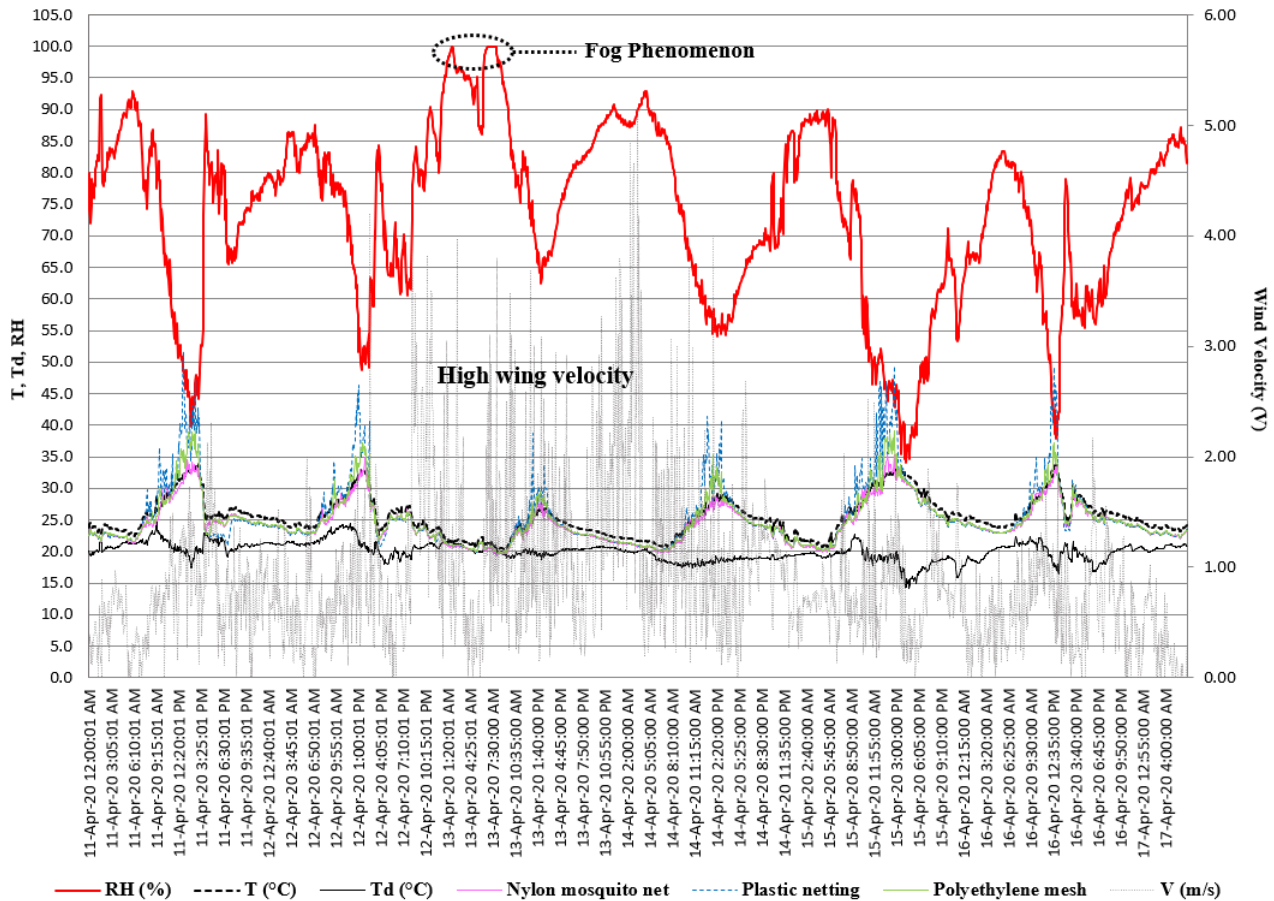

Fig. 13. Comparison graph of surface temperature of three materials and weather conditions for 6 consecutive days during 11 - 17 April 2020

However, on April 13, 2020, when there was fog, the working group surveyed at the cliff area and found that the cliff area had misty wind (like a drop of water) and had more dense mist than the observed area and the wind blown horizontally. The working group therefore agreed that it was appropriate to conduct a second field test by doing it vertically on the cliff and using the above three types of fibers with larger areas to see results more clearly. From the aforementioned experiments, it reveals the possibility of collecting mist water. This is a preliminary experiment to select fibers for further experimentation in a larger scale.

Acknowledgement

The working group would like to thank Electricity Generating Authority of Thailand (EGAT), Thailand for providing financial support for research work.

References

1. T. Ananacha, Thermal Performance of the Clear Block Wall for Ventilation, *GEOMATE Journal*, **23**,96 (2022): 25-31
2. T. Ananacha, W. Puangsombut, J. Hirunlab, Experimental Performance and Numerical Simulation of a Thai Modern Facade Wall,

- International Journal of Ventilation, **14**,3 (2015): 255-263
3. O. Amornletrakul, W. Puangsombut, J. Hirunlab, Field investigation of the small house with the Ventilated Roof Tiles, *Advanced Materials Research*, **931** (2014): 1233-1237
4. N. Lattikapong, O. Amornletrakul, S. Kambung, Analysis of Crutches System to Select and Guide the Design of Crutches Suitable for Different Sizes of Siege Timber and Development of Tree Crutches, *Mathematical Statistician and Engineering Applications*, **71**,4 (2022): 6436-6448
5. S.A. Abdul-Wahab, V. Lea, Reviewing fog water collection worldwide and in Oman, *International Journal of Environmental Studies*, **65**,3 (2008): 487-500
6. A. Ritter, C.M. Regalado, G. Aschan, Fog water collection in a subtropical elfin laurel forest of the Garajonay National Park (Canary Islands): a combined approach using artificial fog catchers and a physically based impaction model *Journal of Hydrometeorology*, **9**,5 (2008): 920-935
7. D.J. Straub, J.W. Hutchings, P. Herckes, Measurements of fog composition at a rural site, *Atmospheric environment*, **47** (2012): 195-205

8. J.A. Johnstone, T.E. Dawson, Climatic context and ecological implications of summer fog decline in the coast redwood region, *Proceedings of the National Academy of Sciences*, **107**,10 (2010): 4533-4538
9. G.J. van Oldenborgh, P. Yiou, R. Vautard, On the roles of circulation and aerosols in the decline of mist and dense fog in Europe over the last 30 years, *Atmospheric Chemistry and Physics*, **10**,10 (2010): 4597-4609
10. S. LaDochy, M. Witiw, The continued reduction in dense fog in the Southern California region: possible causes, *Pure and Applied Geophysics*, **169** (2012): 1157-1163
11. F. Niu, Z. Li, C. Li, K. Lee, M. Wang, Increase of wintertime fog in China: potential impacts of weakening of the Eastern Asian monsoon circulation and increasing aerosol loading, *Journal of Geophysical Research: Atmospheres*, **115**,D7 (2010)
12. F.S. Syed, H. Kornich, M. Tjernstro'm, On the fog variability over south Asia, *Climate dynamics*, **39** (2012): 2993-3005
13. O. Klemm, R.S. Schemenauer, A. Lummerich, P. Cereceda, V. Marzol, D. Corell, J. Van Heerden, D. Reinhard, T. Gherezghiher, J. Olivier, P. Osses, Fog as a fresh-water resource: overview and perspectives, *Ambio*, **41** (2012): 221-234
14. R.S. Schemenauer, P. Cereceda, A proposed standard fog collector for use in high-elevation regions, *Journal of Applied Meteorology and Climatology*, **33**,11 (1994): 1313-1322