

# Energy characteristics of electrotechnological processing of grape cuttings

Nuriddin Markaev<sup>1\*</sup>, Islom Abdiraxmonov<sup>2</sup>, Ikrom Davletov<sup>3</sup>, Babur Tukhtaev<sup>4</sup>

<sup>1</sup>National Research University “Tashkent Institute of Irrigation and Agricultural Mechanization Engineers”, Tashkent, Uzbekistan

<sup>2</sup>Termiz Institute of Engineering and Technology, Tashkent, Uzbekistan

<sup>3</sup>Urganch State University, 220100 Urganch, Uzbekistan

<sup>4</sup>Karshi Engineering and Economic Institute, 180100 Karshi, Uzbekistan

**Abstract.** The article studies the energy properties of energy input into cuttings during electrical processing of a grape stem, taking into account the state of the system in two media (water and cuttings). At the same time, the energy absorbed by grape cuttings depends on the structure of grape cuttings (bast, xylem, core and peel), resistance between the electrode and water ( $R_1$ ,  $R_7$ ), water resistance between the electrode and the grape cut ( $R_2$ ,  $R_6$ ), resistance between the cut grapes and water ( $R_3$ ,  $R_5$ ), stalk resistance of grapes ( $R_4$ ), conductive water resistance ( $R_8$ ) have been determined and scientifically substantiated. As a result, the distance between the electrode and the grape stem ( $l_1$ ), the length of the stem ( $l_2$ ), the distance between the electrodes ( $l_3$ ), the area of electrode coverage with water ( $S_1$ ), the surface of the grape stems ( $S_2$ ), the diameter of the stems 1.2-1.5 cm, the current density increases with time (0-24 hours) in a humid environment by 1-2 A/m<sup>2</sup> at 33.33 V/m<sup>2</sup>, the electric field strength at 133.33 V/m changes by 7-8 A/m<sup>2</sup>, and in a dry environment, the useful energy absorbed by the handle between the electrodes placed inside the working chamber decreases to 0.8-0.68 A/m<sup>2</sup> at 133.33 V/m<sup>2</sup> over time (0-24 hours). It has been established that the absorption depends on the distance ( $l$ ), processing voltage ( $U$ ), and time of exposure to electric current ( $\tau$ ).

## 1. Introduction

The most important indicator of the rooting of grape cuttings is the speed of their rooting. In order to improve the development and quality of seedlings, grape cuttings are additionally processed before planting, the purpose of which is to accelerate root formation, and many studies have been carried out on this subject with different results. In particular, according to the research of AI Derendovskaya, during vegetative propagation from grape cuttings, root formation in them is never one hundred percent. He put forward the opinion that the different physiological state and hormonal activity of the pen depend on the content of plastic substances. Experiments of Radchevsky P.P. show that the processes of root formation in cuttings depend not only on the degree of their maturity, but also on other factors, including hormonal (active), as well as on the method of processing and the physiological state. According to Glebova S.V., Radchevsky P.P., when preparing cuttings for growing grape seedlings, it is necessary to take into account their biological and volumetric conditions.

The process of rooting grape cuttings is very energy intensive and requires at least 12% carbohydrates, i.e. sugars and starches, to form good roots. If these substances are sufficient, pencils are considered sufficient. According to A.G. Matushkin, cuttings can propagate the entire length of the vine, but he found that cuttings cut from the top form better roots by 2-10%, and found that pre treatment of cuttings before planting leads to an increase in power cuttings. Part of the cuttings planted without any treatment may not take root, while the other part may first give leaves and stems, and then dry out. This is mainly due to the fact that the root is not yet sufficiently formed. The initial growth of the branches in the paddock occurs due to the nutrients and moisture accumulated in them in the past year. If these reserves are used up before the formation of roots, then the developing shoots will wither. Therefore, it is important to accelerate the formation of roots in the cuttings. From these ratios, we can conclude that grape cuttings should be processed before planting, and this, in turn, will increase the rate of root formation and the number of roots in them, which will lead to increased resistance.

---

\*Corresponding author: markayev88@mail.ru

Today, in the development of agriculture, there is a problem of influencing the cultivated object to mobilize the potential of varieties. Therefore, at present, more and more attention is paid to the use of various influencing factors to improve the quality of sowing seeds, shorten the growing season, improve root formation, processing during the storage of planting material, etc. In our opinion, the most promising factors of influence are electrophysical effects.

The current state of the art is to control various stimuli to accelerate root formation in vine cuttings, including various electromagnetic field energy states (magnetic field, electric field, electric current, electromagnetic waves, electric discharge, pulsed electromagnetic field) and various plant life. through electrophysical influences, showing that it is possible to direct it in the right direction as a result of active intervention.

At the present stage of developing technologies for growing grape seedlings, one of the important tasks is to accelerate the formation of roots in cuttings and increase sustainability by increasing the number of roots, increasing the number of seedlings and reducing costs.

It should be noted that if the balance between the formation of roots and the growth of new branches in grape cuttings is disturbed, i.e., with later root formation, the cuttings dry out. According to Abdurakhmonova S.Kh., the blueing of seedlings grown from grape cuttings treated before planting depends on the methods of processing and the physiological state of the cuttings. Therefore, it is important to treat grape cuttings with the above methods before planting. The initial electrical treatment of grape cuttings before planting is carried out by absorbing various forms of electromagnetic field energy (EMF) in the environment. In addition to the thermal effect, EMME also has a mechanical, chemical effect and has a certain effect on biological systems. It is possible to change the electrical energy or directly use the effects of "improperty" during electrical action on a biological object (grape shoot) [19, 20].

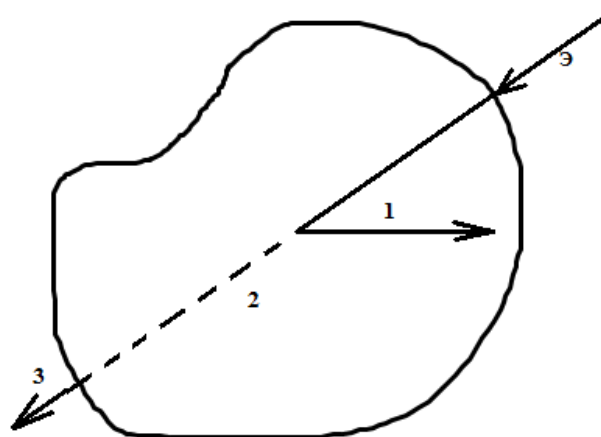

**Fig. 1.** Impact of electromagnetic field energy on the environment

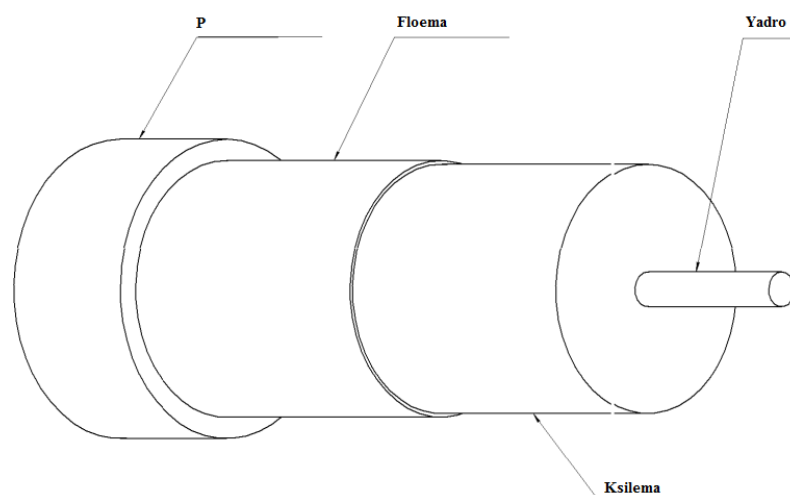

**Fig. 2.** The structure of the stem of a grape cutting

It is known that part of EMME introduced into any environment is absorbed by the treated organism, part passes and part returns (see Fig. 1). As we know from the course of electrical engineering, the work done during electrical

processing occurs due to the absorbed energy. Therefore, the use of various efficient methods and their correct choice is one of the important stages of introducing energy into the technological environment. Today, in order to increase the level of root formation and resistance in vine cuttings, before planting, pre-treatment is carried out in various ways (mechanical, physiological, chemical, traditional, electrophysical, etc.).

One of the effective methods is electrophysical (electric field, magnetic field, electric current, pulsed electromagnetic field, etc.) methods [13,14,15]. In electro-treatment of vine cuttings before planting, the determination of the structure of the cuttings and the determination of the environment during processing and the corresponding energy input determine the effectiveness of the treatment (Figure 2). Before planting grape cuttings, it will be possible to describe their individual parts as elements of an electrical circuit.

The resistance of the layers of the phloem and xylem of the shoot is the same, but the resistance of the nucleus differs from them. As the voltage applied to the pen tissue increases, the dependence of the resistance on the applied frequency approaches a linear state.

## 2. Methods

The characteristics of the grape stem and agricultural products related to the plant world, that is, plant elements, are determined by the ways in which the processed stem is connected to an electrical source and its structure. According to A.G. Kudryakov, the most correct method of pre-treatment of grape cuttings with electric current before planting is the supply of electricity to the places of cuttings of grape cuttings through a liquid conductive solution [1,6]. In this regard, special attention is paid to the development of methods and means to treat cuttings of grape seedlings with infrared, electromagnetic rays and electric current, accelerate their development, homogenize their vegetative development and improve their quality to save energy and resources [2,3]. In this regard, one of the topical issues is the development of various technologies and devices that allow accelerating the flow of biophysical processes in them by treating them with low-voltage alternating electric current before planting them in cuttings where grape seedlings are harvested, as well as substantiating its technological parameters.

Today, high-quality grape seedlings are grown mainly by vegetative methods, in which the safety of grape cuttings is on average 65-80%, and 20-25% of planted cuttings remain immature [7]. It is possible to increase the stability of grapes by electrical treatment before planting in cuttings, but in this case it is important to study ways to introduce energy into cuttings and determine ways to effectively introduce energy [4]. The value of the energy input during electrical stimulation of grape cuttings plays an important role, and the determination of the method of its input characterizes the effectiveness of the study [17,18]. Therefore, the analysis of the current density passing through the pre-treated grape cuttings depending on the processing voltage and time is considered one of the topical issues. The main purpose of the study is to develop a system for solving the above problems on a scientific basis. According to GOST 28181-89, the moisture content of grape cuttings must be at least 46% [8]. When pencils are immersed in water, the moisture content in it increases with time, and, accordingly, the electric current passing through it changes with time [8]. A technique for analyzing these cases was developed and experiments based on this technique were carried out. Experiments were carried out on cuttings 50 cm long and 1.2–1.5 cm in average diameter, obtained from the Kora Kishmish grape variety, and placed in a horizontal position in the working chamber.

The exit point of the pen from the working chamber was sealed so that water would not seep through. The distance between the electrodes and the working chamber was 2 mm. The circuit diagram of the experimental stand is shown in Fig. 3.

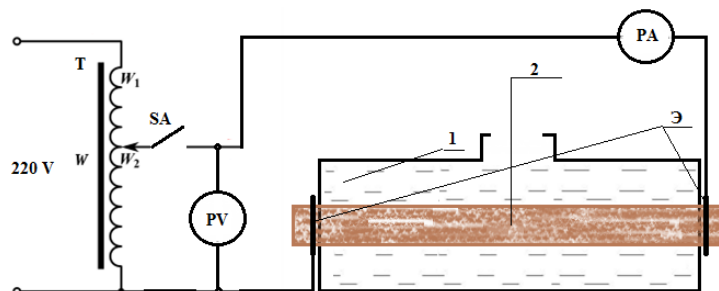

**Fig. 3.** Schematic diagram of the stand for determining the current density passing through the stem of grapes: Э- electrodes are shown in the picture; 1-water; 2 grapevines; PA – milliammeter (LINI-T UT51 multimeter); Electronic voltmeter PV - MT 81

In the experiments, an autotransformer PHO-250-10 was used to regulate the voltage in the electrical circuit. Multimeters brand DT-9205 A and LINI-T UT51 were used to monitor energy parameters and measured (mains

current and voltage) using these meters. Measurements were taken and repeated every hour. Measuring instruments are verified and checked for errors using highly reliable and proven measuring instruments. Needles made of stainless material were used as electrodes. The distance between the electrodes used in the experiment was 50 cm, and the voltage applied to them was 10, 22, 40 Volts. The processing time in the study was 24 hours. To ensure the accuracy of the results, the experiment was repeated 4 times, and the current density passing through the sample handle was calculated using formula (1)  $j$ , A/m<sup>2</sup>.

$$j = \frac{I}{S} \tag{1}$$

in this  $I$  is a vine that goes through the vine, A;

$S$  is the cross-sectional surface of the grapevine, m<sup>2</sup>;

Studies have shown that the processing time ( $\tau$ ) of alternating electric current flowing through the handle, the geometric dimensions of the handle depending on the physiological state (diameter ( $d$ ), surface ( $S$ ) and length of the handle ( $l$ ), network voltage ( $U$ ), distance between electrodes ( $l$ ) and showed the dependence of the current supplied to the pen ( $f$ ).

In studies on the electrical processing of grapevine cuttings, various methods of placing the cuttings in the working chamber were tested [11, 12]. These studies did not study the electrophysical processes when the sludge was not immersed in water, and the study of the current flow through the sludge per unit time for a given production line is a reason for understanding important factors. In order to study and analyze the cases described above, studies were carried out on the condition of the “Kora Kishmish” variety vine with a length of 50 cm and an average diameter of 1.2-1.5 cm. The needle electrodes placed in the handle are made of stainless material.

In the experiment, an RNO-250-10 autotransformer was used to regulate the source voltage in the electrical circuit. Multimeters brand DT-9205 A and LINI-T UT51 were used to monitor energy parameters and measured (mains current and voltage) using these meters. Measurements were taken and repeated every hour. The electrical circuit diagram of the experimental stand is shown in Fig. 4.

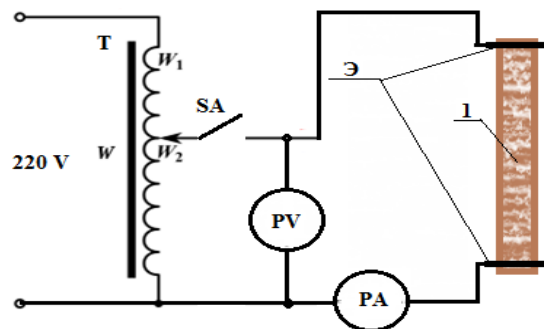

**Fig. 4.** Schematic diagram of a stand for determining the current density passing through a grape stem: 1-grape cuttings; Э - electrodes; PA - milliammeter; PV – voltmeter

### 3. Solving style

The study of the energy characteristics of the electrical circuit during electrical treatment of grape stems characterizes the effectiveness of this electrical stimulation. It is carried out by studying the scheme of technological processes for supplying energy to grape cuttings in a two-media system (see Fig. 5) [1].

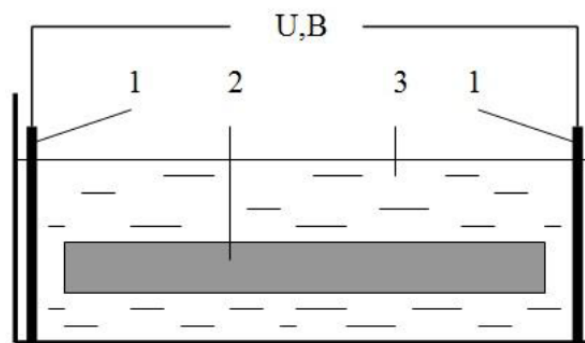

**Fig. 5.** Scheme of supplying grape cuttings with electricity

In this picture there is 1st electrode, 2nd vine, 3rd liquid (water) conducting electric current. In this case, based on the circuit for supplying grape cuttings with electricity, it will be possible to create an electrical switching circuit, which is shown in Fig. 2. When constructing an equivalent switching circuit, resistances are presented in series and in parallel [9,10]. Figure 6 shows a diagram of replacing the electrical treatment of grape cuttings.

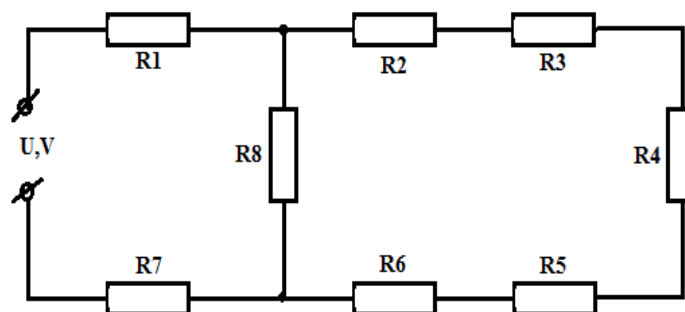

**Fig. 6.** Scheme for replacing the electrical treatment of grape cuttings

In this figure,  $R_1, R_7$  are the resistances between the electrode and water;  $R_2, R_6$  - water resistance between the electrode and the vine;  $R_3, R_5$  - resistance between the grape stem and water;  $R_4$  - vine resistance;  $R_8$  - conductive water resistance. Considering that the electrodes used during pre-treatment with alternating electric current before planting on grape cuttings have the same geometric dimensions and are made of the same metal, given that the initial electrically treated grape cuttings have a cylindrical shape along the entire length, the electrical switching circuit described is can be simplified somewhat.

Based on the switching circuit for the electrical processing of grape cuttings, it is possible to simplify the general circuit by taking into account the resistances  $R_1=R_7, R_3=R_5$  and  $R_2=R_6$ , the values of which are the same. Through this theoretical view, we have a simplified general scheme of treatment with alternating electric current before planting on cuttings of Blackcurrant grapes, shown in Figure 7.

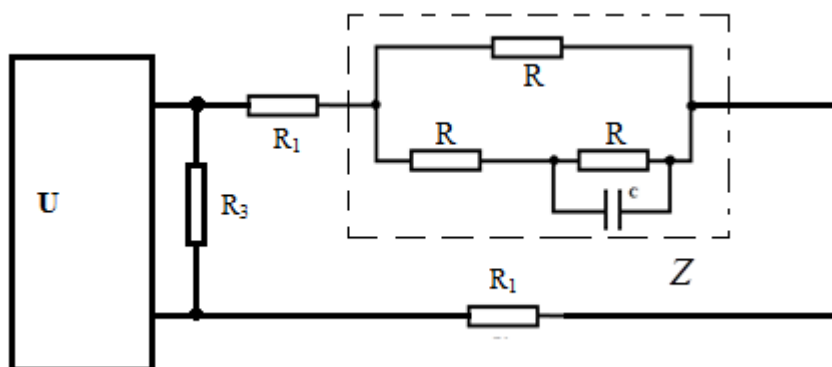

**Fig. 7.** Simplified general diagram of electrical processing of grape cuttings

In this figure,  $R_1$  is the water resistance between the electrodes and the handle; Pin-grape resistance;  $R_3$  is the resistance of water conducting electric current. Therefore, in calculation books carried out during the initial treatment of grapevine cuttings with alternating current, the resistance of the bars can be neglected, given that the values of the transient resistance in the bars are small. Thus, it is worth noting that when the input energy for the technological line passes through the technological scheme in the form of alternating electric current, all its elements absorb a certain amount of energy (Visrof - for electric heating of water, Vkalamcha - for electric heating). pen heating). The total energy consumption in this technological process, i.e. during pre-treatment of cuttings of vines of the “Kora Kishmish” variety before planting with alternating electric current, can be described by expression (2)

$$W_o = 2W_1 + W_2 + W_3 \tag{2}$$

in this  $W_1$  is the energy absorbed between the water and the handle;  $W_2$  – Energy absorbed by the vine;  $W_3$  - energy absorbed by water (energy used to heat water). In this dual-medium (water and pen) technology, the energy absorbed by the pen is used for electrical stimulation and technological work [1,5,6]. The energy absorbed in the remaining elements of the electrical processing chain of grape stems does not perform useful work and is lost [7]. Taking the

useful energy consumed by the sludge as  $W_f$ , and the energy expended in the production line as  $W_i$ , we can write the following.

$$W_f = W_2 \quad W_i = 2W_1 + W_3 \quad (3)$$

The system of energy electrodes, which are introduced into the production line, are connected in a certain way to each other and to the power supply network; electric current is introduced into the electrically processed medium through electrodes with the same geometric dimensions. This depends on the structure and size of the object being processed, the shape and size of the electrodes and the distance between them. For an electrode system with flat electrodes, each of which has a width ( $v$ ), a height ( $h$ ) and a distance between them ( $l$ ), the phase resistance can be written as

$$R_f = \frac{\rho l}{S} = \frac{\rho l}{\epsilon h} \quad (4)$$

where  $l$ ,  $h$ ,  $v$  are the geometric parameters of the system of flat parallel electrodes. For a system consisting of a two-medium (water and feather) process mode,  $R_f$ - resistance can be written as follows.

$$R_f = \frac{(2R_1 + R_2) \cdot R_3}{(2R_1 + R_2) + R_3} \quad (5)$$

where  $R_1$  is the total resistance of water between the electrodes and handles;  $R_2$ -grape resistance;  $R_3$  is the resistance of water conducting electric current. The values of the unknown resistances  $R_1$ ,  $R_2$ ,  $R_3$  in formula (5) can be determined as follows.

$$R_1 = \frac{l_1 \cdot \rho_{cyb}}{S_1} \quad (6)$$

$$R_2 = \frac{l_2 \cdot \rho_{kall}}{S_2} \quad (7)$$

$$R_3 = \frac{l_3 \cdot \rho_{suv}}{S_1 - S_2} \quad (8)$$

in this  $l_1$  is the distance between the electrode and the vine, m;  $l_2$  - length of the vine, m;  $l_3$  - distance between electrodes, m;  $S_1$  - electrode area covered with water, m<sup>2</sup>;  $S_2$  - surface of grape cuttings, m<sup>2</sup>.

The second component, water, is used to provide useful energy to the cuttings in AC technology before planting grapevine cuttings. In this case, part of the total energy used in the process is absorbed by the high concentration of water and goes to heat it. To characterize the effective electrotechnology for growing grape seedlings (pre-treatment with alternating electric current before planting on grapevine cuttings), it is necessary to determine the absorbed energies in a two-component system and optimize the process.

Turchanin O. S., Kovalenko Yu. A., Titarevsky A. L., Shebeteev V. A and Sbitneva N. In his studies, he described energy using the Joule-Lenz formula when calculating the total Wum energy consumption absorbed in a two-component (water and pen) system:

$$W_{ym} = \gamma_{muz} \cdot U^2 \quad (9)$$

So, based on the law of conservation of energy, in technology based on the second system of components, the useful energy  $W_1$  absorbed by grapevine cuttings can be expressed as follows.

$$W_1 = W_0 - W_2 \quad (10)$$

in this:  $W_1$  - useful energy absorbed by grapevine cuttings;

$W_2$  - energy used for electrical heating of water;

In his studies, V.A. Petrukhin determined expression (11) during the electrical treatment of fruit tree cuttings, that is, he described the degree of susceptibility  $S_{st}$  during the electrical treatment of fruit tree cuttings as follows.

$$S_{mym} = 1 - \left( S_0 - \frac{\gamma}{\alpha} \right) \cdot e^{-\alpha(W-W_0)} - \frac{\gamma}{\alpha} \quad (11)$$



in this:  $S_0$  – initial resistance, %;  $\gamma = \beta/R_H$  – marking is on;  $\beta$  – proportionality coefficient,  $\Omega/J$ ;  $R_T$  – current resistance,  $\Omega$ ;  $R_H$  – initial resistance,  $\Omega$   $\alpha$  – proportionality coefficient,  $1/J$ . The energy used to electrically stimulate grapevine cuttings can be written as follows.

$$P_1 = I \cdot U \cdot \cos \varphi = U \cdot I \cdot \frac{g}{y} = U \cdot I \cdot Z \cdot g = g \cdot U^2 = \frac{1}{R_\kappa} \cdot U^2 \quad (12)$$

in this:  $g_a$  – active conductivity, S;  $y$  - total capacity, S;  $Z$  - total resistance,  $\Omega$ ;

Useful energy ( $W_{qal.foy}$ ) absorbed by the vine during electrical heating of vine cuttings is expressed as follows

$$W_1 = P_1 \cdot \tau = \frac{\tau}{R} \cdot U^2 = U^2 \frac{\tau}{R} = U^2 \frac{\tau}{\rho_\kappa \frac{l}{S}} \quad (13)$$

in this:  $\tau$  - time of electrical treatment of grapevine cuttings, h;  $l$  - length of the grapevine stem, cm;  $S$  – cross-sectional surface of the feather,  $mm^2$ ;  $\rho_\kappa$  - resistivity of grapevine cuttings, Ohm-m.

The Joule-Lenz formula for a system of plane-parallel electrodes is used for the energy used to electrically heat water.

$$W_2 = P_2 \cdot \tau = U^2 \frac{\tau}{R_s} = U^2 \frac{\tau}{\frac{\rho_s l}{S}} = U^2 \frac{\tau}{\frac{\rho_s l}{(\epsilon \cdot h)}} \quad (14)$$

in this:  $\rho_s$  - water resistivity, Ohm-m;  $l$  - distance between the plane-parallel system of electrodes, m;  $\epsilon$ ,  $h$  - electrode system sining geometrics ulchamlari, cm; Substituting this expression (13) and (14) into expression (11), we obtain:

$$S_{mym} = 1 - \left( S_0 - \frac{\gamma}{\alpha} \right) \cdot e^{-\alpha \left( \gamma_{muz} \cdot U^2 - U^2 \frac{\tau}{\frac{\rho_s l}{(\epsilon \cdot h)}} \right)} - \frac{\gamma}{\alpha} \quad (15)$$

Simplifying the illustrated expression (17), we obtain the theoretical expression (18)

$$S_{mym} = 1 - \left( S_0 - \frac{\gamma}{\alpha} \right) \cdot e^{-\alpha \left( U^2 \frac{\tau}{\rho_q \frac{l}{S}} \right)} - \frac{\gamma}{\alpha} \quad (16)$$

From this expression it can be seen that the degree of resistance of grapevine cuttings depends on the processing voltage ( $U$ ), processing time ( $\tau$ ) and the distance between the electrodes ( $l$ ). According to the research results, the theoretical expression (16) characterizes the effectiveness of treatment with alternating electric current before planting grape cuttings.

#### 4. Results and Discussion

As a result of the conducted research, it is possible to obtain the processing voltage ( $U$ ), processing time ( $\tau$ ) and the distance between the electrodes ( $l$ ) as influencing factors during the pre-treatment of grape cuttings of the “Kishmish Black” variety with alternating electric current. before landing, and these factors. If research is carried out to change it, this will make it possible to increase the capacity of the pens

Based on the information presented, one can put forward such an idea when studying the energy properties of the technology used in the primary treatment with alternating electric current before sowing. Individual parts of technological processes can be considered as elements of an electrical circuit in increasing the level of root formation by electrical stimulation of cuttings and thereby increasing the level of resistance, which allows us to fully understand this technology. When applying power to the cuttings, the distance between the electrode and the grape cutting ( $l_1$ ), the length of the grape cutting ( $l_2$ ), the distance between the electrodes ( $l_3$ ), the water coverage area of the electrode ( $S_1$ ) and the surface of the cutting must be taken into account the grape cuttings ( $S_2$ ). Figure 8 shows a graph of the density of passage of the vine through the vine versus the processing time.

Analyzing the results of the experiment, we can conclude that the current density passing through the stem of the grapevine is not the same over time. In a time-dependent state, it increases for 14-15 hours and then decreases. In the early stages of processing, grape cuttings become saturated with liquid and their resistance decreases due to increased humidity. As the pen's resistance decreases, the amount of current passing through it increases. Once the treatment

time exceeds 14-6 hours, the current passing through it decreases due to decreased conductivity of the feather cells (cell damage). From this experience we can conclude that it is advisable to stop the duration of treatment after 14-16 hours during the initial treatment with alternating electric current before planting the cuttings on the vine. This over-processing results in the cuttings not taking root due to the negative impact on the cellular tissues.

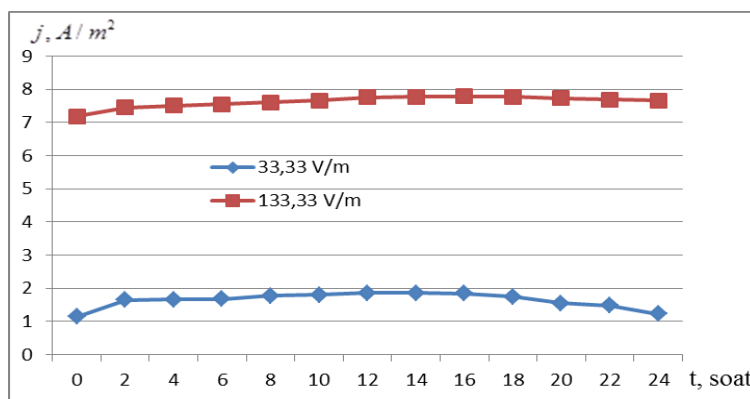

**Fig. 8.** Graph of the density of vines passing through grape cuttings versus processing time

The distance between the electrodes on the experimental bench was 50 cm, and the voltage applied to them was 10, 22, 40 Volts. The experiment was repeated 4 times and the observation time in each repetition was 24 hours. The current density passing through the grapevine in the sample was calculated using the formula  $j$ , A/m<sup>2</sup> (2.32). It has been observed that the flow of electrical current decreases over time when grape cuttings are exposed to the technique described above. The results of the experiment are presented in Figure 9.

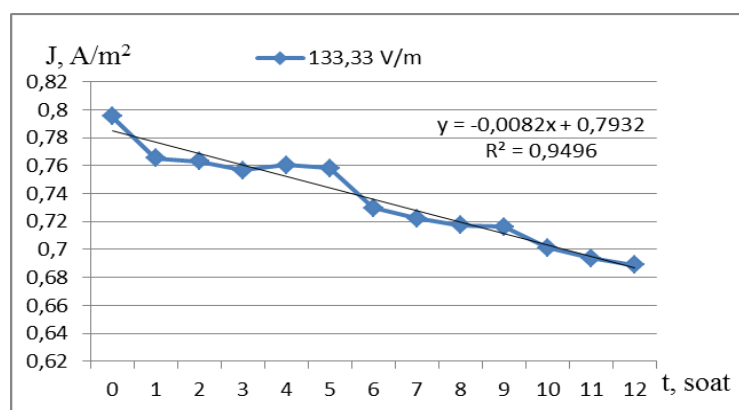

**Fig. 9.** Graph of the dependence of the current density passing through the grape cuttings on the treatment time (without immersion in water)

The experiment was carried out on a 50 cm long grapevine cutting. It was observed that the alternating current through the initially treated handle decreased over time. It can be concluded that a pencil placed between the electrodes becomes dehydrated over time and its resistance increases. This process is directly proportional to the state, that is, as the resistance increases, the current flowing through the pen decreases. According to GOST 28181-89 and GOST 1191-2009, it is noted that when planting grape cuttings, their humidity should be at least 46% [8]. Therefore, it is best to treat grape cuttings in water with AC pre-treatment before planting, taking into account maintaining sufficient moisture and ease of energy input.

## 5. Conclusion

When studying the energy characteristics of the electrical circuit when introducing energy for electrical stimulation of grape stems, the following conclusions were made:



1. Grape cuttings of the “Kishmish Black” variety can be accelerated by electrical treatment. As a result, it was determined that individual parts of the technological processes of electrical processing of pencils can be considered as elements of an electrical circuit.
2. In the replacement circuit of electrical processing before planting on grape cuttings, between the electrode and water ( $R_1$ ,  $R_7$ ), water between the electrode and grape cuttings ( $R_2$ ,  $R_6$ ), between grape cuttings and water ( $R_3$ ,  $R_5$ ), cutting of grapes is taken into account ( $R_4$ ) and conductive water resistance ( $R_8$ ). As a result, it was found that it was possible to fully understand this technology.
3. Electrical treatment is possible before planting grape cuttings. As a result, it was established that when electrically processing grapevine cuttings, it is necessary to take into account the moisture content of the cuttings at least 46% according to GOST 28181-89.
4. It is important to determine the value of the total resistance of water ( $R_1$ ), the resistance of the grape stem ( $R_2$ ) and the resistance of water conducting electric current ( $R_3$ ) when studying the technological modes of a two-media environment (water and paddock). system. As a result, it was possible to determine the energy absorbed by grape stems.
5. One of the important parameters is to take into account the geometric dimensions of grape cuttings before planting them. As a result, according to GOST 1191-2009 (O'zDSt 1191:2009) and GOST 28181-89 and according to the results of experiments, the diameter of pencils is in the range of 1.2-1.5 cm, the value of the cross-sectional area ( $S$ ) is in the range of 113, 04-176.625 mm<sup>2</sup>.
6. Electrical treatment of grape cuttings before planting increases the level of resistance of the cuttings. In this case, the energy introduced into the processed medium depends on various factors and its values have been studied practically and theoretically. As a result, it was determined that at the initial stage it is necessary to take into account the distance between the electrodes placed in the working chamber ( $l$ ), the operating voltage ( $U$ ) and the time of exposure to electric current ( $\tau$ ). electrical treatment before planting cuttings on the vine.
7. When applying energy to the vines, the distance between the electrode and the vine ( $l_1$ ), the length of the vine ( $l_2$ ), the distance between the electrodes ( $l_3$ ), the area covered by the electrode with water ( $S_1$ ) should take into account the surface of the vines ( $S_2$ ), which turned out to be one of the important factors of electric acceleration.

## References

1. A.G. Kudryakov, Stimulation of root formation of grape cuttings by an electric field: Authorization, Dissertation for Candidate of Technical Sciences, Krasnodar (1999)
2. S.V. Glebova, P.R. Panteleevich, Peculiarities of manifestation of regenerative ability in cuttings of technical grape varieties Bianca, Viorica and Riton, *Scientific Journal of KubGAU* **114**(10), 5-20 (2015)
3. L.V. Kravchenko, N.P. Doroshenko, G.V. Sokolova, The role of biotechnology in improving the phytosanitary status of vine plantations, Organizational and economic mechanism of the innovation process and priority problems of scientific support for the development of the industry, Krasnodar (2003)
4. P.P. Radchevsky, Influence of a pulsed electromagnetic field on the generative activity of grape cuttings of the moldova variety, *Scientific Journal of KubSAU* **95**(01), 4-24 (2014)
5. A. Dardeniz, S. Tayyar, S. Yalsin, Influence of low-frequency electromagnetic field on the vegetative growth of grape cv. Uslu, *Journal of Central European Agriculture* **7**, 389-396 (2006)
6. A. Bokiev, N. Nuralieva, S. Sultonov, A. Botirov, and U. Kholiknazarov, Diversification of energy supply to the agricultural sector in the conditions of Uzbekistan, *E3S Web of Conferences* **264**, 04022 (2021)
7. A.S. Berdishev, N.M. Markaev, J. Hasanov, Effects of electrophysical processing on the development of vine root roots, *E3S Web of Conferences* **264**, 04090 (2021)
8. A.S. Berdishev, O.Q. Matchonov, N.M. Markayev, Use of Electrophysical Methods to Accelerate Root Growth in Grapes, *Int J Advanced Research in Science, Engineering and Technology* **8**, 18510-18514 (2021)
9. M. Ibragimov, D. Akbarov, I. Tadjibekova, Investigation of asynchronous electric motor winding in heating mode and drying mode to prevent moisture, *E3S Web of Conferences* **365**, 04019 (2023)
10. A. Radjabov, N. Eshpulatov, S. Nabiyev, Reserves for energy efficiency in processing and storage of fruit and vegetable products in the republic of Uzbekistan, *Int J Electrical and Electronics Engineering Research* **8**, 1-10 (2018)
11. T. Kizildeniz, M. Movila, M.M. Bettoni, S. Abdullateef, S. Candar, Grapevine Propagation Method with Two Temperature Controlling Process, *Viticulture Studies* **2**, 045-053 (2022)
12. A. Radjabov, M. Ibragimov, N.M. Eshpulatov, O. Matchonov, Improving the energy performance of ozone generators used in agricultural ecology, *Journal of Physics: Conference Series* **1399**, 055060 (2019)
13. M. Ibragimov, N. Eshpulatov, O. Matchanov, Electrical technology of moisture content reduction of industrial-grade cotton seeds, *IOP Conference Series: Materials Science and Engineering* **883**(1), 012135 (2020)

14. R.S. Sayfutdinov, U.D. Mukhitdinov, N.M. Eshpulatov, Increasing reactivity of cotton celluloses for chemical processing, *IOP Conference Series: Materials Science and Engineering* **883**(1), 012133 (2020)
15. J.S. Bayzakova, N.K. Abdildin, Zh.S. Shynybay, Zh.S. Chingenzhinova, A.S. Berdyshev, N.M. Eshpulatov, O.Q. Matchonov, Sh.B. Yusupov, Methodology for conducting an optimization experiment for harvesting dry short-stalked grain crops, *IOP Conf. Series: Earth and Environmental Science* **614**, 012118 (2020)
16. M. Ibragimov, N. Eshpulatov, O. Matchanov, Substantiation of the optimal parameters by processing with electric contact methods to decrease the moisture content of technical seeds, *IOP Conf. Series: Earth and Environmental Science* **614**, 012018 (2020)
17. A. Radjabov, M. Ibragimov, N. Eshpulatov, The study of the electrical conductivity of Apples and Grapes as an object of electrical processing, *E3S Web of Conferences* **226**, 00002 (2021)
18. N. Eshpulatov, T. Khalmuradov, R. Khalilov, A. Obidov, S. Nurmanov, D. Omonov, Theoretical substantiation of the influence of electric pulse processing on the process of obtaining juice from grapes and fruits, *E3S Web of Conferences* **264**, 04086 (2021)
19. M. Ibragimov, D. Akbarov, M. Fayziyev, R. Beytullaeva, K. Nimatov, Kh.S. Safarov Analysis of the methods of diagnosing asynchronous motors according to vibration indicators, *IOP Conference Series: Earth and Environmental Science* **1142**(1), 012031 (2023)
20. N. Eshpulatov, D. Yusupov, L. Akabirov, D. Dinikulov, N. Toshmamatov, Investigation of the influence of microwave energy on the kinetics of the release of juice from apples, *IOP Conference Series: Earth and Environmental Science* **1112**, 012081 (2022)
21. A. Turdiboyev, U. Khaliknazarov, D. Akbarov, M. Kholiyarov, S. Abdullaeva, T. Butaev, Study on the energy efficiency issues in extracting fat and oils from cotton seeds, *AIP Conference Proceedings* **2686**, 020019 (2022)
22. A. Turdiboyev, D. Akbarov, A. Mussabekov, T. Toshev, J. Niyozov, Study on the improvement the quality of drinking water via electrochemical pulse treatment, *IOP Conference Series: Earth and Environmental Science* **939**(1), 012021 (2021)
23. A. Turdiboyev, N. Aytbaev, M. Mamutov, T. Toshev, N. Kurbonov, Study on application of electrohydraulic effect for disinfection and increase of water nutrient content for plants, *IOP Conference Series: Earth and Environmental Science* **1142**(1), 012027 (2023)
24. A. Turdiboyev, D. Akbarov, The new production of electrotechnology cottonseed oil and energy efficiency rating, *IOP Conference Series: Materials Science and Engineering* **883**(1), 012115 (2020)