

Development of pneumatic shoe press machine with integrated real-time cloud database system for SMEs footwear productivity

Nur Kholis¹, Yunus^{2*}, Rizdana Galih Pambudi², Ade Priyo Widhikdho³, and Theodorus Wiyanto Wibowo²

¹Department Electrical Engineering, State University of Surabaya, Surabaya, Indonesia.

²Departement Mechanical Engineering, State University of Surabaya, Surabaya, Indonesia.

³School of Mechanical and Manufacturing Engineering, The University of New South Wales, Sydney NSW, Australia

Abstract. Abstract. This innovative effort focused on advancements in the shoe-making process by introducing a state-of-the-art pneumatic shoe press integrated with a real-time cloud database system tailored to the needs of small and medium-sized enterprises (SMEs). This research aims to design and engineer a state-of-the-art pneumatic shoe press capable of printing complex designs on leather footwear. This machine can collect, send, and store production data in a cloud-based database, so as to monitor and analyze their manufacturing operations in real-time. The research methodology utilizes a structured approach from the design, manufacturing, assembly, operational testing, performance evaluation, and data analysis stages. The application of a pneumatic shoe press integrated with a real-time cloud database system provides various benefits for SMEs in the footwear industry. The system's advantage lies in the use of a real-time cloud database that allows SMEs to gain immediate access to production data. The machine is capable of printing complex designs with high precision in one minute per pair of shoes. The product quality is good, so it can meet the standards of the shoe industry. This research successfully developed a pneumatic shoe press integrated with a real-time cloud database system, which can improve the productivity and quality of SMEs in the shoe industry. This technological innovation simplifies the manufacturing process, ensures the best product quality, and provides real-time production data.

1 Introduction

Fashion is a very interesting and profitable business [1]. In the era of the revolution industrial 4.0, all humans need fashion that can reflect themselves, because in this era, first impression is very important [2]. A person who gives a good first impression will make himself accepted, appreciated, and recognized by others [3]. One of the important fashion products to support your appearance is shoes [4]. Sidoarjo is one of the districts

* Corresponding author: yunus@unesa.ac.id

that has many micro, small and medium enterprises (MSMEs), almost 306,481 [5]. UD. Bajarsari is one of the MSMEs in Sidoarjo that produces shoes. The shoe products produced include school shoes, office shoes, loafers, and safety shoes. UD. Bajarsari in producing shoes still uses simple equipment and is done manually, so the quality and quantity of production are still low [6]. However, UD. Banjari still has to carry out production because it already has many customers who order from the place and the number of shoe users is increasing [7]. The process of making shoes at UD. Bajarsari can be seen in Fig. 1.



Fig. 1. Shoe production process with manual tools

The production equipment used in general still uses conventional tools, making it difficult to produce goods effectively and efficiently. The condition of the existing equipment is quite poor and it is necessary to update the tools and machines to improve the quality and quantity of production [8]. The process of gluing the sole and upper is done by gluing the upper to the sole, then followed by beating and pressing using a hammer so that the upper and sole can adhere firmly as shown in Fig. 2.



Fig. 2. Shoe gluing process

The manual gluing process is not very effective and efficient and has many weaknesses. The pressing process given cannot be evenly distributed throughout the base and sides of the shoe circumference, so the bond strength is uneven [9]. The manual gluing process results in less pressure applied because the sole of the shoe will be deformed due to hammer blows and pressure. The adhesion of the results of manual gluing is less strong and the gluing process can only be done one by one, so it requires a large enough emphasis that makes labor tired quickly so that work productivity decreases. The time required for one shoe gluing process takes one minute for one shoe which includes the base and the perimeter of the shoe. The production capacity is only one pair of shoes every two minutes for one worker [10].

Shoes produced by UD. Banjari when viewed from the aspect of physical appearance quality, shoe products produced by this small shoe industry already look good, namely shiny, trendy, and impressive like classy and expensive shoes so that they make confidence for those who wear them. However, from the aspect of bonding strength between the sole and upper, the quality is still not good, the bonding strength is still uneven for the entire circumference of the glued shoe. The low quality and quantity of production is a challenge for MSMEs in developing their business [11]. This is because many consumer orders cannot be fulfilled in accordance with the amount and time requested by consumers. As a result, many consumers are disappointed and cannot wait according to the time period promised by MSMEs. Some consumers even choose to cancel their orders or look for products from other MSMEs that can meet their needs. Shoe products can still be improved in terms of strength, evenness of bonding strength, and uniformity through the application of appropriate production technology that is effective and efficient [12]. Based on the events in the field that occur, it is necessary to apply appropriate technology to overcome or help improve the quality of shoes.

The appropriate technology is to design and engineer a state-of-the-art pneumatic shoe press capable of printing complex designs on leather footwear. The machine is designed to collect, send, and store production data in a cloud-based database. Advanced pneumatic shoe presses can monitor and analyze their manufacturing operations in real-time. The shoe press uses a pneumatic system, applying intense pressure to all parts of the glued shoe, resulting in a very strong and even bonding quality of the leather shoes.

2 Methods

The method that will be carried out in the implementation of the first research is a survey or field observation of several MSMEs to see firsthand the shoe production process and interviews. The results of surveys and interviews were analyzed to find out the problems faced by shoe MSMEs. The results of the analysis found that there are problems that are important to be resolved immediately, namely the process of pressing the upper glue with the sole which is done manually using hammer pressure and screw press, requires a lot of energy, a long time, and the resulting adhesive strength is not optimal, because the pressure is uneven. If these problems are not resolved immediately, they can make shoe MSMEs lose in trade competition. This research activity is carried out through several stages, which include the design, manufacturing, machine testing, and evaluation stages.

2.1 Design

The design stage starts with designing the design and description of the machine to be developed. When making a design assisted with 3D Modeling software. After the design has been completed, then proceed in making a blueprint.

2.2 Manufacturing

Selection of materials that match the standards used to design the machine. After all the materials are collected, continue assembling the machine according to the predetermined design. The main components are first made, after completion at this stage then proceed to testing the machine.

2.3 Testing

When manufacturing is complete, it is then continued by testing the function of using this automatic pneumatic system shoe press machine to find out the performance in the partner's small shoe industry.

2.4 Evaluation

After the pneumatic shoe press machine with an integrated real-time cloud database system is completed, an evaluation is carried out during the process of making the machine until it is used by partners.

3 Result and discussion

Based on observations at MSMEs and information provided related to the operational conditions, the process of pressing the upper gluing with the sole carried out by MSMEs uses a conventional system. The process of pressing the upper gluing with the sole is done manually using hammer pressure and screw press which requires a lot of energy and a long time. However, the adhesion strength produced is not optimal because the pressure applied is uneven.

To overcome these problems, this research initiated the manufacture of a leather shoe sole and upper adhesive press machine with an automatic pressure sensor integrated with a real-time cloud database system. Before the manufacturing process, the first step is to design a drawing of a shoe-pressing machine using an automatic air pressure (pneumatic) system. The machine design is made with the help of 3D modeling applications. The results of the press machine design can be seen in Fig. 3.

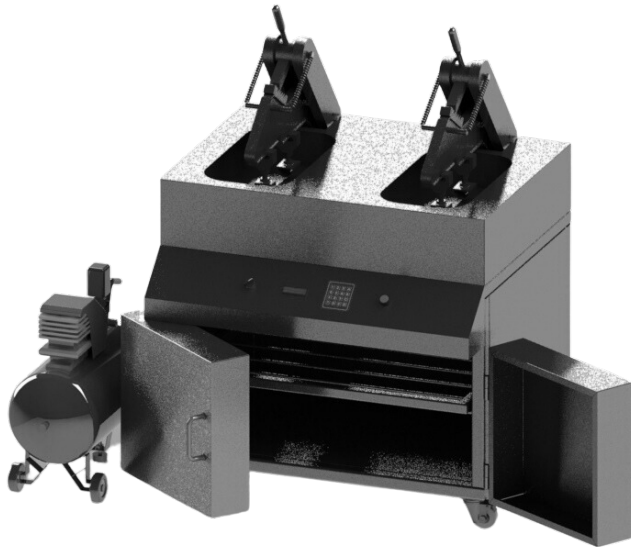

Fig. 3. Design the design of the pressing machine

Based on Fig. 3, the press consists of a pneumatic press control, retaining lever, serrated arm, compressor, and electric motor. This press machine is also equipped with a real-time cloud system. The press machine can apply strong pressure to all parts of the glued shoes, resulting in a very strong and evenly distributed quality of leather shoes. The provision of air pressure can be controlled by a pneumatic press control equipped with a timer or timer that can be adjusted as needed. This press machine is also integrated with a cloud database storage system that aims to facilitate data collection of production that has been produced based on daily production results^[13].

This Pneumatic Shoe Press Machine with an Integrated Real-time Cloud Database System has an engine motor used for the compressor uses a 1 PK engine motor. This machine is also equipped with a shoe rack that can be used to store shoes that have been pressed. The resulting automatic pneumatic system shoe press machine and machine trials in shoe SMEs can be seen in Fig. 4.

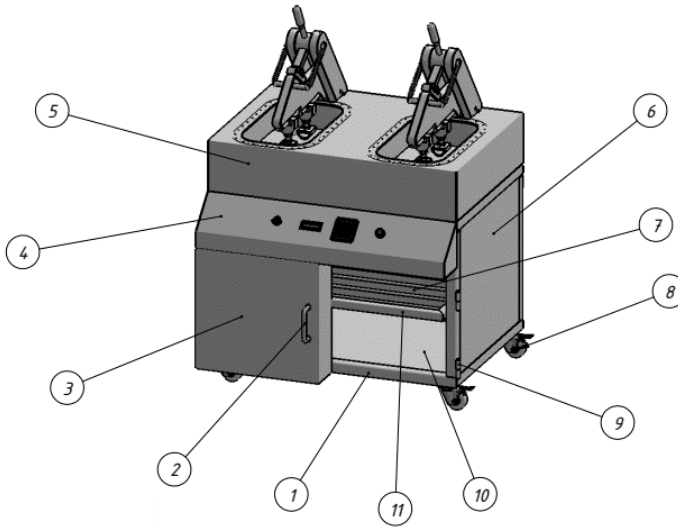

Fig. 4. Detail machine

Table 1. Machine description

No	Description	Specification
1	Frame Unit	Stainless stell 201
2	Door Handle	
3	Door	
4	Control Panel	Acrylic
5	Top Cover	Stainless stell 201
6	Side Cover	
7	Rear Cover	
8	Wheels	Plastic
9	Hinge	Stainless stell 201
10	Bottom Cover	
11	Shelf	

The working principle of this automatic pneumatic system shoe press machine is (1) connect the compressor electric motor cable to the electric power source; (2) press the ON / OFF button on the machine in the ON position; (3) set controls, including the desired pressure and the length of time of pressing; (4) the compressor turns on to accommodate air; (5) place the shoes on the leather membrane; (6) lock the shoe holder arm; (7) press the start button to start the air-filling cycle automatically; (8) holding the pressure according to the input time, the faucet opens automatically so that the air can escape; (9) lift the shoe holder arm and take the shoes that have been pressed from the membrane; (10) do the next pressing starting from the fifth step to the ninth step; and (11) turn off the machine if the shoe pressing process is complete. The machine specifications can be seen in Table 2.

Table 2. Specification machine

No	Description	Grade
1	Dimension	940cm x 840cm x 1300cm
2	Engine Power	0.5 PK
3	Capacity	2 shoes
4	Pressure	3-4 Bar
5	Counting	Raspberry PI
6	Control box	1. Emergency 2. ON/OFF 3. Buttom counter
7	Display	LCD

The function test experiment of using this automatic pneumatic shoe press was conducted to determine the performance in a small shoe industry [14]. The machine function test process was carried out by: 1) gluing the sole and upper that has been installed in the sulas; 2) preparing a pair of shoes to be pressed; 3) placing a pair of shoes on top of two leather membranes on the pressing machine; 4) lock the shoe holder arm; 5) press the start button to start the air filling cycle automatically; 6) hold the pressure according to the inputted time, the faucet opens automatically so that the air can escape; 7) lift the shoe holder arm and take the finished pressed shoe from the membrane; 8) lift the shoe holder and take the finished pressed shoe from the membrane, 9) the shoe pressing process is complete.

Based on the machine performance testing carried out, the data obtained is that it takes ± 20 seconds to press a pair of shoes with details: 1) the time for placing shoes on the pressing membrane is approximately five seconds, the pressing time is held for 10 seconds to produce a strong bond, and for taking shoes from the membrane is 5 seconds, so that the production capacity is three pairs of shoes/minute, twice as large as the manual gluing process of a pair of shoes/minute. The results of the function test comparing manual shoe pressing with using an automatic pneumatic shoe press are shown in Table 3.

Table 3. Results of manual shoe pressing trials using an automatic pneumatic shoe pressing machine in pairs/minute.

Test to -		1	2	3	4	5	Average
Manual	Number of shoes	25	25	25	25	25	25
	Pressing time	25'39"	28'03"	26'11"	30'12"	25'43"	27'9"
Machine	Number of shoes	25	25	25	25	25	25
	Pressing time	12'35"	12'37"	13'23"	12'55"	13'02"	12'54"

Based on Table 3, it can be seen that the results of the total shoes pressed using an automatic pneumatic shoe pressing machine are collected in cloud data storage which makes it easier for MSMEs to collect data on production that has been produced based on

daily production. The results of shoes from the automatic pneumatic system shoe press have good quality. This machine can be said to have passed the criteria of the research. The machine can also increase production to meet demand from consumers who also do not forget about quality [15]. Evaluation of the development of this press machine still cannot be fully controlled by the machine and still needs human intervention.

4 Conclusion

This research successfully developed a pneumatic shoe press integrated with a real-time cloud database system, which can improve the productivity and quality of SMEs in the shoe industry. This technological innovation simplifies the manufacturing process, ensures the best product quality, and provides real-time production data. This machine can almost double shoe production with an average time required of only 12'54". The press results have a strong and even bond.

References

1. M. Pradana, Reventiary, *Jurnal Manajemen* **6** (2016)
2. N. Maryanti, R. Rohana, M. Kristiawan, M. *International Journal of Educational Review* **2**, 1 (2020)
3. M. R. Leary, *Self-presentation: Impression management and interpersonal behavior* (Routledge, 2019)
4. S. Supardi, et al., *Jurnal Ekonomi Manajemen Sistem Informasi* **4** (2023)
5. A. Sudaryanto, I. A. Maruta, *SOCIETY: Jurnal Pengabdian dan Pemberdayaan Masyarakat* **1** (2020)
6. M. Suyanto, M. Abdulrahim, *Journal Community Service Consortium* **1** (2020)
7. I. Novizar, Z. Mahjali, A. Agustiar, *Jurnal Bisnis Tani* **1** (2015)
8. L. Holbeche, *Aligning human resources and business strategy* (Routledge, 2022)
9. S. Anwar, E. Wahjudi, Yunus, *Jurnal Pengabdian Pada Masyarakat* **1** (2022)
10. K. Alvarez, D. Aldas, J. Reyes, *Towards lean manufacturing from theory of constraints: a case study in footwear industry*, In 2017 International conference on industrial engineering, management science and application (ICIMSA), IEEE, (2017, June)
11. S. Bhat, E. V. Gijo, A. M. Rego, V. S. Bhat, *TQM Journal* **33**, 2 (2021)
12. J. Patnaik, B. Bhowmick, *Technol Anal Strateg Manag* **34** (2022)
13. C. Xu, et al., *Int J Digit Earth* **15** (2022)
14. M. S. Gad, K. A. A. Yehia, A. A. Abdelhakeem, *Fullerenes, Nanotubes and Carbon Nanostructures* **26**, 11 (2018)
15. M. Font-i-Furnols, L. Guerrero, *Meat Sci.* **193**, 108941 (2022)